

**Model M3452**  
**Combination Braking Module with**  
**Integrated Transistor and Resistor**

**Customer Reference Manual**  
**For "B" and "C" Chassis Modules**

**Bonitron, Inc.**  
Nashville, TN



*An industry leader in providing solutions for AC drives.*

## **ABOUT BONITRON**

Bonitron designs and manufactures quality industrial electronics that improve the reliability of processes and variable frequency drives worldwide. With products in numerous industries, and an educated and experienced team of engineers, Bonitron has seen thousands of products engineered since 1962 and welcomes custom applications.

With engineering, production, and testing all in the same facility, Bonitron is able to ensure its products are of the utmost quality and ready to be applied to your application.

The Bonitron engineering team has the background and expertise necessary to design, develop, and manufacture the quality industrial electronic systems demanded in today's market. A strong academic background supported by continuing education is complemented by many years of hands-on field experience. A clear advantage Bonitron has over many competitors is combined on-site engineering labs and manufacturing facilities, which allows the engineering team to have immediate access to testing and manufacturing. This not only saves time during prototype development, but also is essential to providing only the highest quality products.

The sales and marketing teams work closely with engineering to provide up-to-date information and provide remarkable customer support to make sure you receive the best solution for your application. Thanks to this combination of quality products and superior customer support, Bonitron has products installed in critical applications worldwide.

## AC DRIVE OPTIONS

In 1975, Bonitron began working with AC inverter drive specialists at synthetic fiber plants to develop speed control systems that could be interfaced with their plant process computers. Ever since, Bonitron has developed AC drive options that solve application issues associated with modern AC variable frequency drives and aid in reducing drive faults. Below is a sampling of Bonitron's current product offering.

## WORLD CLASS PRODUCTS

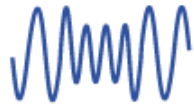

### Undervoltage Solutions

Uninterruptible Power for Drives  
(DC Bus Ride-Thru)  
Voltage Regulators  
Chargers and Dischargers  
Energy Storage



### Power Quality Solutions

12 and 18 Pulse Kits  
Filtering  
Noise and Transient Suppression  
Power Factor Correction

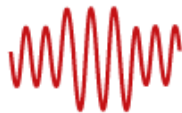

### Overvoltage Solutions

Braking Transistors  
Braking Resistors  
Transistor/Resistor Combo  
Line Regeneration  
Dynamic Braking for Servo Drives



### Common Bus Solutions

Single Phase Power Supplies  
3-Phase Power Supplies  
Common Bus Sharing Diodes  
Isolation Diodes  
Bus Filter Capacitance



### Green/Sustainable Solutions

Voltage Boosters  
(for Solar and Wind Applications)  
Line Regeneration  
Power Factor Correction



### Portable Maintenance Solutions

Capacitor Formers  
Battery Testers  
Capacitor Testers  
Capacitor Dischargers

<b>1. INTRODUCTION</b>	<b>1</b>
1.1. Who Should Use	1
1.2. Purpose and Scope	1
1.3. Manual Version and Change Record	1
Figure 1-1: Typical M3452 Complete Module	1
<b>2. PRODUCT DESCRIPTION / FEATURES</b>	<b>2</b>
2.1. Related Docs	2
2.2. Part Number Breakdown	2
Table 2-1: Part Number Breakdown	2
Table 2-2: AC Voltage Rating	3
Table 2-3: Resistors	3
Table 2-4: Chassis Codes	3
2.3. General Specifications	3
Table 2-5: Specifications	3
2.4. General Precautions and Safety Warnings	4
<b>3. INSTALLATION INSTRUCTIONS</b>	<b>5</b>
3.1. Environment	5
3.2. Unpacking	5
3.3. Mounting	5
3.3.1. Mounting the M3452	5
Figure 3-1: Prohibited Mounting Arrangement	6
Figure 3-2: Recommended Placement and Required Minimum Mounting Clearances	6
3.4. Wiring and Customer Connections	7
3.4.1. Power Wiring	7
Figure 3-3: TS1 Termination Information	7
Table 3-1: Power Wiring Specifications	7
3.5. Typical Configurations	8
Figure 3-4: Field Connections	8
<b>4. OPERATION</b>	<b>9</b>
4.1. Functional Description	9
4.2. Features	9
4.2.1. Indicators	9
4.2.2. Crowbar Circuit	9
4.3. Startup	9
4.3.1. Pre-Power Checks	9
4.3.2. Startup Procedure and Checks	10
4.4. Operational Adjustments	10
<b>5. MAINTENANCE AND TROUBLESHOOTING</b>	<b>11</b>
5.1. Periodic Testing	11
5.2. Maintenance Items	11
5.3. Troubleshooting	11
5.3.1. Control power light not illuminated	11
5.3.2. DC bus light not illuminated	11
5.3.3. Blown DC bus fuse	12
5.3.4. Fan runs constantly	12
5.3.5. Fan doesn't run	12

---

# Table of Contents

5.3.6.	Module over-temp, or module seems too hot .....	13
5.3.7.	Drive trips on overvoltage .....	13
5.3.8.	Braking light flickers .....	13
5.3.9.	Braking light stays on all the time.....	13
5.4.	Technical Help – before you call .....	14
<b>6.</b>	<b>ENGINEERING DATA .....</b>	<b>15</b>
6.1.	Ratings Charts .....	15
	Table 6-1: Standard Model Ratings.....	15
6.2.	Turn On Voltages .....	15
	Table 6-2: Turn-on Voltages.....	15
6.3.	Watt Loss .....	16
	Table 6-3: Watt Loss .....	16
6.4.	Certifications .....	16
6.5.	UL 508A Short Circuit Current Rating .....	16
6.6.	Fuse/Circuit Breaker Sizing and Rating .....	16
6.7.	Dimensions and Mechanical Drawings .....	17
	Figure 6-1: Enclosure Dimensional Outline (Styles “B” & “C”) .....	17
6.8.	Block Diagrams .....	18
	Figure 6-2: Block Diagram.....	18
<b>7.</b>	<b>APPLICATION NOTES .....</b>	<b>19</b>
7.1.	Sizing your Braking Requirements .....	19
7.1.1.	Horsepower to Watts.....	19
7.1.2.	Peak Amperage.....	19
7.1.3.	Ohmic Value.....	19
7.1.4.	Duty Cycle .....	20
7.1.5.	Continuous Rating.....	20
7.2.	Common Bus Application Note .....	20
7.3.	Bonitron Line Regeneration Modules .....	21

*This page intentionally left blank.*

## 1. INTRODUCTION

### 1.1. WHO SHOULD USE

This manual is intended for use by anyone who is responsible for integrating, installing, maintaining, troubleshooting, or using this equipment with any AC Drive System.

Please keep this manual for future reference.

### 1.2. PURPOSE AND SCOPE

This manual is a user's guide for the Model M3452 Complete Braking Module. It will provide the user with the necessary information to successfully install, integrate, and use the M3452 Complete Braking Module in a variable frequency AC drive system.

In the event of any conflict between this document and any publication and/or documentation related to the AC drive system, the latter shall have precedence.

### 1.3. MANUAL VERSION AND CHANGE RECORD

Fusing information was updated in Rev 05d of this manual.

**Figure 1-1: Typical M3452 Complete Module**



## 2. PRODUCT DESCRIPTION / FEATURES

Bonitron's Complete Braking Module provides drive protection from over-voltage faults due to regenerated voltage. The Complete Braking Module works with any AC drive system that uses a fixed DC bus by dissipating the excess regenerated energy as heat using resistive loads switched across the DC bus.

Regenerative braking occurs when an induction motor is decelerating or the shaft of the motor is being overhauled by a load. In this case, the motor acts as a generator, and causes the DC bus of the Variable Frequency Drive to rise. If the DC bus voltage is not controlled, the VFD will trip on DC Bus Overvoltage and stop regulating the motor speed. The regenerated energy must be dissipated as heat or returned to the power line.

Resistive braking is typically used in applications with infrequent regeneration. With this system, the regenerated energy is dissipated as heat. When the DC bus of the drive rises, the braking transistor or "chopper" is turned on connecting a resistor to the DC bus until the voltage drops to a lower level.

Dissipating this heat may be impractical in applications with more frequent regeneration. In these applications, the higher cost of the Bonitron M3345 Line Regen as compared with resistive braking is quickly offset because the regenerated energy, which is returned to the AC line with near unity power factor, can be used to power other equipment.

### 2.1. RELATED DOCS

The M3452 line of Dynamic Braking Transistor Modules is compatible with a number of other Bonitron modules, which may be required to meet overall system operational requirements.

The M3575R represents a line of enclosed Resistive Load Modules rated up to 150hp peak. The M3775RK represents another line of Resistive Load Banks rated up to 3 megawatts.

The M3575W Crowbar Module offers protection for the Resistive Load Bank by blowing a fuse link between the transistor and resistor. This insures that the resistor is disconnected from the DC bus in the case of over temperature or other fault.

### 2.2. PART NUMBER BREAKDOWN

**Table 2-1: Part Number Breakdown**

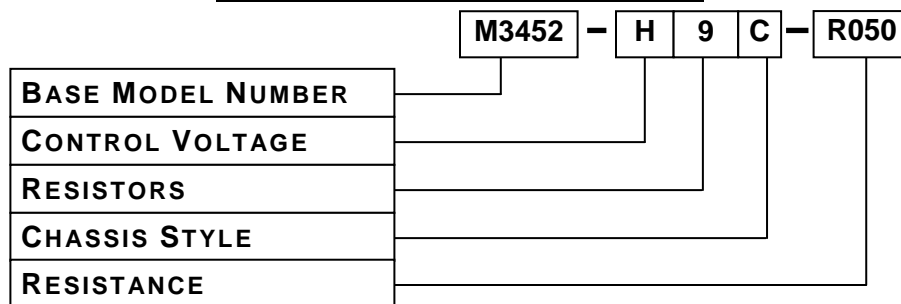

#### **BASE MODEL NUMBER**

The Base Model Number for the Complete Braking Module is **M3452**.

#### **VOLTAGE RATING**

The Voltage Rating indicates the AC voltage level for the drives in the system.

**Table 2-2: AC Voltage Rating**

RATING CODE	NOMINAL AC LINE
L	230VAC
H	460VAC
C	575VAC

**RESISTORS**

The Resistor Quantity is indicated by a numeric code.

**Table 2-3: Resistors**

RATING CODE	RESISTOR QUANTITY
2	2 Resistors
3	3 Resistors
6	6 Resistors
8	8 Resistors
9	9 Resistors

**CHASSIS SIZE**

The Chassis Style code represents the chassis and size of the Complete Braking Module.

**Table 2-4: Chassis Codes**

CHASSIS CODE	RESISTORS	TYPE	DIMENSIONS (H x W x D)
B	2, 3, 6	Type 1	18.25 x9.50 x 8.50
C	8, 9	Type 1	18.25 x11.50 x 10.50

**RESISTANCE**

The Resistance is indicated by an "R" followed by the 3-digit number representing the ohmic value of the internal load bank.

**2.3. GENERAL SPECIFICATIONS**

**Table 2-5: Specifications**

PARAMETER	SPECIFICATION
Connections	Input AC line Drive DC Bus Ground
Input AC Line	230, 460, 575VAC Single Phase; Rated Voltage $\pm 10\%$ ; 50/60 Hz
Operating Temp	0 to 50°C
Storage Temp	-20 to + 65°C
Humidity	Below 90 % non-condensing
Atmosphere	Free of corrosive gas and conductive dust

## 2.4. GENERAL PRECAUTIONS AND SAFETY WARNINGS



**DANGER!**

- **HIGH VOLTAGES PRESENT!**
- **NEVER ATTEMPT TO OPERATE THIS PRODUCT WITH THE ENCLOSURE COVER OPENED!**
- **NEVER ATTEMPT TO SERVICE THIS PRODUCT WITHOUT FIRST DISCONNECTING POWER TO AND FROM THE UNIT.**
- **ALWAYS ALLOW ADEQUATE TIME FOR RESIDUAL VOLTAGES TO DRAIN BEFORE REMOVING THE ENCLOSURE COVER. VERIFY VOLTAGE ON UNIT WITH VOLTMETER BEFORE SERVICING.**
- **FAILURE TO HEED THESE WARNINGS MAY RESULT IN SERIOUS BODILY INJURY OR DEATH!**



**CAUTION!**

- **THIS PRODUCT WILL GENERATE HIGH TEMPERATURES DURING OPERATION.**
- **THIS PRODUCT SHOULD BE INSTALLED ACCORDINGLY ON NON-FLAMMABLE SURFACES WITH CLEARANCES OF AT LEAST 2" ON THE TOP AND SIDES, AND A MINIMUM OF 6" ON THE FRONT AND BOTTOM.**
- **ALWAYS ALLOW AMPLE TIME FOR THE UNIT TO COOL BEFORE ATTEMPTING SERVICE ON THIS PRODUCT.**
- **NO USER-SERVICEABLE PARTS ARE CONTAINED WITHIN THIS PRODUCT. INOPERABLE UNITS SHOULD BE REPLACED OR RETURNED FOR EVALUATION AND/OR REPAIR BY QUALIFIED TECHNICIANS**
- **BEFORE ATTEMPTING INSTALLATION OR REMOVAL OF THIS PRODUCT, BE SURE TO REVIEW ALL DRIVE AND/OR RESISTIVE LOAD DOCUMENTATION FOR PERTINENT SAFETY PRECAUTIONS.**
- **INSTALLATION AND/OR REMOVAL OF THIS PRODUCT SHOULD ONLY BE ACCOMPLISHED BY A QUALIFIED ELECTRICIAN IN ACCORDANCE WITH NATIONAL ELECTRICAL CODE OR EQUIVALENT REGULATIONS.**

**ANY QUESTIONS AS TO APPLICATION, INSTALLATION, OR SERVICE SAFETY SHOULD BE DIRECTED TO THE EQUIPMENT SUPPLIER.**

### 3. INSTALLATION INSTRUCTIONS



*Installation and/or removal of this product should only be performed by a qualified electrician in accordance with National Electrical Code or local codes and regulations.*

Proper installation of the Model M3452 Complete Brake Module should be accomplished following the steps outlined below. Be sure to refer to the AC Drive instruction manual as these steps are performed. Since most start-up difficulties are the result of incorrect wiring, every precaution must be taken to assure that the wiring is done as instructed. All items must be read and understood before the actual installation is started. Please direct all installation questions that may arise during the installation and start up of this product to the equipment supplier or system integrator.

#### 3.1. ENVIRONMENT

The module should be installed in an area protected from moisture and falling debris. Buildup of dust or debris may cause poor performance and possibly a failure. Operating in a wet environment can pose a shock hazard.

#### 3.2. UNPACKING

Upon receipt of this product, please verify that the product received matches the product that was ordered and that there is no obvious physical damage to the unit. If the wrong product was received or the product is damaged in any way, please contact the supplier from which the product was purchased.

#### 3.3. MOUNTING

##### 3.3.1. MOUNTING THE M3452

The installation site for the module should be chosen with several considerations in mind:

- Unit should not be exposed to falling debris or condensation.
- Refer to Figure 3-2 for minimum mounting clearances.
- The M3452 must be properly oriented for proper heat flow through the units.
- The M3452 must be mounted with the rear surface of the unit to the mounting surface. **Unit should be mounted vertically** as shown in Figure 3-2. Failure to do so can result in overheating and damage to the unit or surrounding equipment.
- **Do Not** mount the unit upside-down or on the underside of a mounting surface as shown in Figure 3-1.
- **Do Not** mount unit in horizontally with side parallel to the mounting surface or floor as shown in Figure 3-1.

**Figure 3-1: Prohibited Mounting Arrangement**

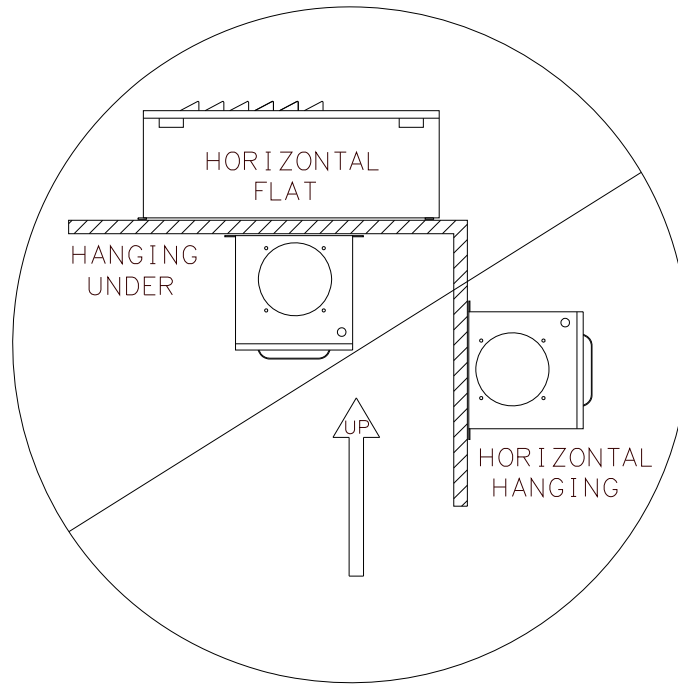

**Figure 3-2: Recommended Placement and Required Minimum Mounting Clearances**

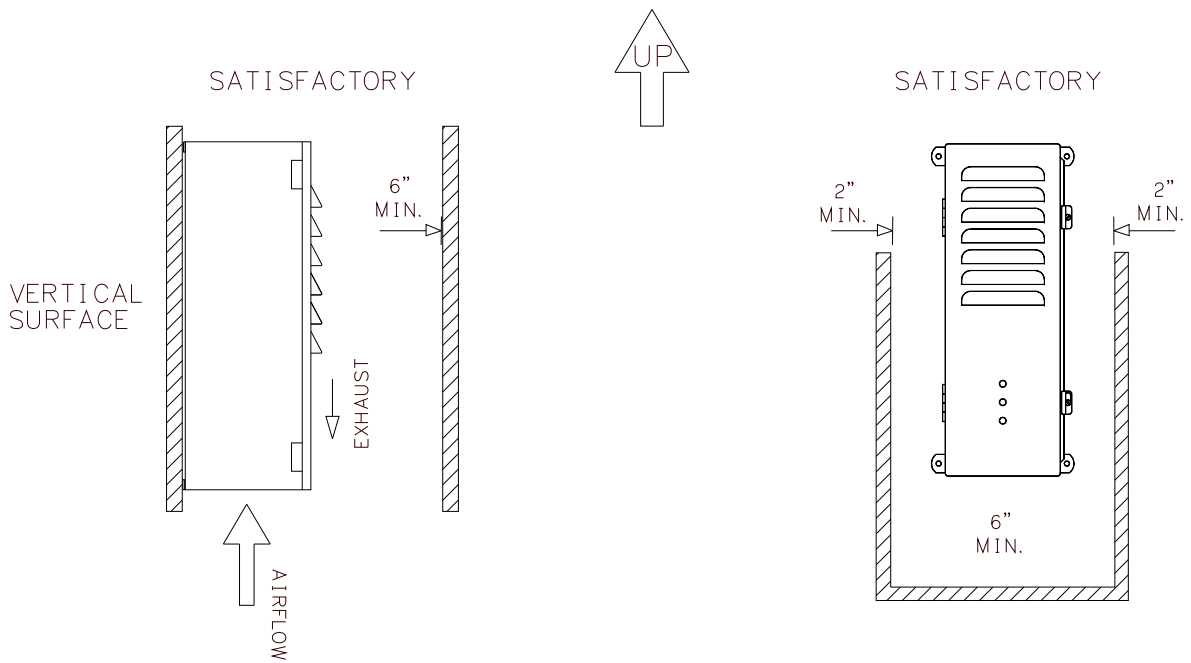

### 3.4. WIRING AND CUSTOMER CONNECTIONS

#### 3.4.1. POWER WIRING



*Only qualified electricians should perform and maintain the interconnection wiring of this product. All wiring should be done in accordance with local codes.*

Wire size should be selected in accordance with local codes, according to the current rating of the braking transistor. Use copper conductors rated 75°C. In general, the wire type should be selected by the nominal system AC voltage and the current rating of the module.

**Figure 3-3: TS1 Termination Information**

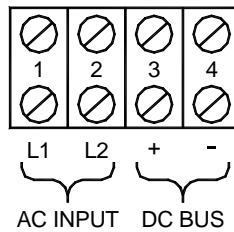

**Table 3-1: Power Wiring Specifications**

TERMINAL	CONNECTION	TORQUE	WIRE SIZE
DC+, DC-, RES+, RES-	#10-32 Phillips Screw	20 lb-in	#10-14 AWG CU
GND	¼" Stud	10 lb-in	#10-14 AWG CU

##### 3.4.1.1. AC BUS CONNECTION

The AC connection to the drive provides power for the fans and control circuit of the braking unit. It must be connected for the braking unit to operate. The amount of AC input power is very low compared to the capacity of the braking unit. Refer to Section 6 for full power requirements for each unit.

##### 3.4.1.2. DC BUS CONNECTION

The DC bus input may be connected to the DC bus of an AC drive, the DC output of a diode sharing unit, or to a common DC bus. If a reactor or choke is being used in the bus, make sure the actual connection is in parallel with filter capacitors of the drive/inverter.

Make sure that the DC bus connection polarity is correct. Improper polarity connections carry a high risk of damaging drive equipment if energized.

Some drives have a connection to an internal braking transistor, commonly marked B+ or B-. Do **not** use this connection. Connect **only** to the DC bus terminals. Refer to your drive manufacturer's documentation or technical support for further information.

Please see Section 7 for further application notes.

### 3.4.1.3. GROUNDING REQUIREMENTS

All units come equipped with either a ground terminal or ground stud that is connected to the module chassis. Ground the chassis in accordance with local codes. Typically, the wire gauge will be the same as is used to ground the attached drive.

## 3.5. TYPICAL CONFIGURATIONS

**Figure 3-4: Field Connections**

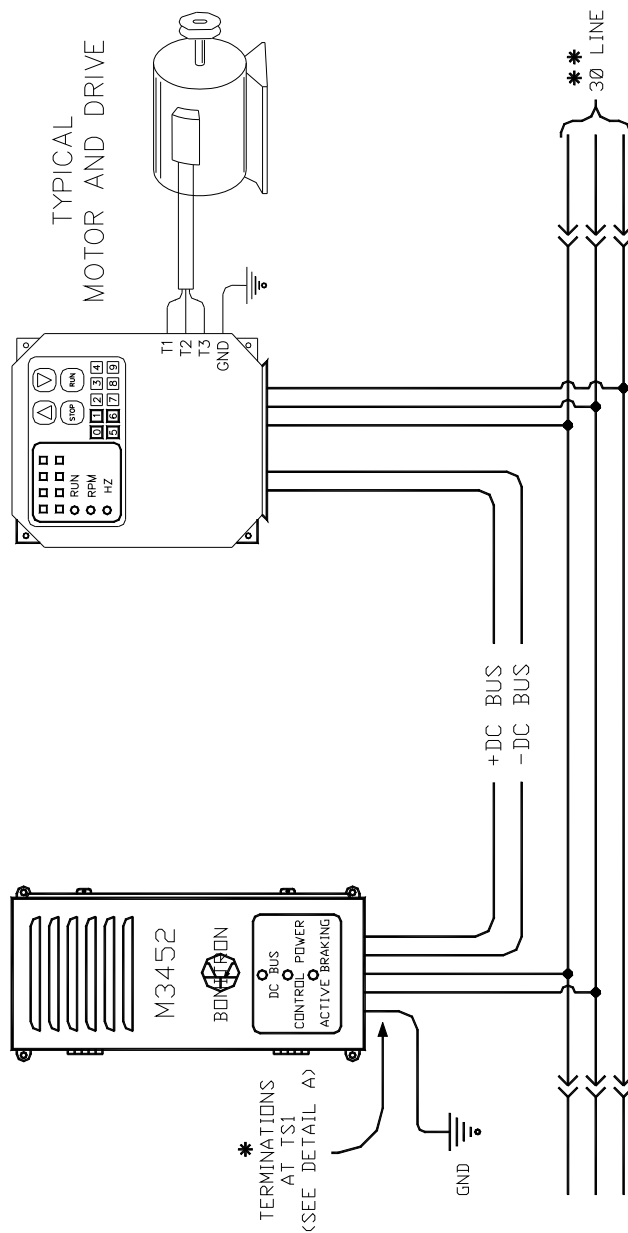

~NOTES~

## 4. OPERATION

### 4.1. FUNCTIONAL DESCRIPTION

When the drive's DC bus voltage exceeds a fixed setpoint, the Complete Braking Module's control electronics turns on an IGBT transistor connecting the resistor load across the DC bus. When the DC bus goes down to a lower level, the IGBT turns off.

The braking module may switch at different frequencies, depending on the amount of braking force or deceleration needed.

### 4.2. FEATURES

#### 4.2.1. INDICATORS

##### 4.2.1.1. DC BUS

The DC Bus indicator illuminates when the voltage between the DC+ and DC- terminals is greater than 50VDC.



*Do not use this light as an indication that the DC bus is safe to work on! Always check the DC bus with a working voltmeter before servicing equipment, as the DC bus light may be broken!*

##### 4.2.1.2. CONTROL POWER

This indicator illuminates when control power is applied to the unit, and indicates that the control circuit is functioning.

##### 4.2.1.3. ACTIVE BRAKING

This indicator illuminates when the chopper IGBT is on. When the drive is idle, this light should not be on. During braking, this light will be on or flashing, depending on the amount of braking energy.

#### 4.2.2. CROWBAR CIRCUIT

The integral crowbar circuit in the unit clears the input fuse in the event of a severe overtemperature or other fault. This is a failsafe circuit that ensures the resistor is disconnected from the DC bus.

### 4.3. STARTUP



*Bonitron Complete Braking Modules are designed to be used with stand-alone or common DC bus drive/inverter systems with bus capacitors. When using the Bonitron modules on common bus systems, special considerations may apply. Refer to and review the Application Notes found in Section 7 later in this manual prior to energizing this type of system!*

#### 4.3.1. PRE-POWER CHECKS

Ensure that all connections are tight, DC bus polarity is correct, and that all customer wiring is of the proper size for operational requirements. Check for exposed conductors or bare spots that may lead to accidental contact.

## 4.3.2. STARTUP PROCEDURE AND CHECKS

Apply AC power to the drive system and the Complete Braking Module. On the Complete Braking Module, verify the following:

- AC control voltage is within tolerance. Refer to Table 2-5 for voltages and tolerances.
- Green **Control Power** indicator is **ON**.
- Amber **DC Bus** indicator is **ON**.
- Red **Active Braking** indicator is **OFF**. **Immediately** turn off all power if the indicator is **ON** to avoid possible load bank overheating and/or other equipment damage.
- Verify the drive system DC bus voltage, and make sure it is within tolerance for the drive system.

If any of the above conditions are not as indicated, turn off all power and allow ample time for all system energy sources to discharge. **Use a voltmeter to verify that all voltages are zero and have discharged!** Check all wiring connections and jumper configurations. Refer to the Troubleshooting Section of this manual for more information. For further assistance, contact Bonitron technical support.

Once the pre-checks are complete, the drive system can be enabled. Once the drive system is operational, run the motors with light deceleration, and decrease the braking time until the red **Active Braking** indicator lights.

## 4.4. OPERATIONAL ADJUSTMENTS

No adjustments are necessary for this module. All regulation points are factory adjusted, and should not be changed in the field. If your module is not functioning properly, refer to the Troubleshooting Section of this manual, or contact Bonitron for assistance.

## 5. MAINTENANCE AND TROUBLESHOOTING

Repairs or modifications to this equipment are to be performed by Bonitron approved personnel only. Any repair or modification to this equipment by personnel not approved by Bonitron will void any warranty remaining on this unit.

### 5.1. PERIODIC TESTING

At least every other month, visually inspect the front panel indicator lights to be sure they are operating correctly. With control power applied, the green **Control Power** indicator should be illuminated. The amber **DC Bus** indicator will be on if the drive bus is above 50VDC. The red **Active Braking** indicator will only be on or flashing if the module is actively chopping from the DC Bus. There are no operational tests to be performed.

### 5.2. MAINTENANCE ITEMS

Monthly, check the module for buildup of dust, debris, or moisture. Dangerous voltages exist within the module and the buildup of dust, debris, and moisture can contribute to unwanted arcing and equipment damage. Take whatever corrective or maintenance actions are necessary to keep the module clean and moisture free.

Monthly, check the cooling fan and exhaust for any buildup of debris. If they require cleaning **power down the drive system** and blow the debris out with clean dry air as necessary to maintain proper cooling performance. **Note:** After blowing out the fan and/or exhaust, blow off any dust or debris that may have gotten on any of the circuit boards.

### 5.3. TROUBLESHOOTING



*Lethal voltages exist in these systems! Before attempting checks or repair, follow all precautions to insure safe working conditions, including lockout/tagout procedures, and verifying safe working voltages with proper meters. Do not rely on the DC Bus indicator to insure a safe condition.*



*Only qualified personnel familiar with variable frequency AC drives and associated machinery should plan or implement the installation, start-up and subsequent maintenance of the system. Failure to comply may result in personal injury, death and/or equipment damage.*

Feel free to call Bonitron at any time if the equipment appears to be having problems.

#### 5.3.1. CONTROL POWER LIGHT NOT ILLUMINATED

- Check Control Voltage input level on customer terminal TS1-1, 2. Refer to Table 2-2: AC Voltage Rating to be sure it is within 10%. The modules can be ordered with various control voltages, and the proper voltage must be used for the module's configuration.
- If the control voltage is correct, the indicator may be burned out, and need replacement.

#### 5.3.2. DC BUS LIGHT NOT ILLUMINATED

This can be a normal condition in systems where DC Bus power and logic control power are not applied or removed simultaneously, and indicates that there is less than 50VDC on the inverter bus.



*Do not use this light as an indication that the DC bus is safe to work on! Always check the DC bus with a working voltmeter before servicing equipment, as the DC bus light may be broken!*

- Use a DC voltmeter to check the Bus Voltage at the module terminals DC bus + and DC bus -.
- If voltage above 50VDC exists, and the light is not illuminated, the light or control circuit may be damaged, and the unit should be returned for repair.
- The main DC bus fuse may be blown. See next Section.

### 5.3.3. BLOWN DC BUS FUSE



*Do not replace a blown DC bus fuse and reapply power to the system without determining the cause.*

*This usually indicates serious problems exist and proceeding in this manner carries a high risk of creating additional equipment damage!*

*Contact Bonitron before changing the fuse.*

Possible causes for a blown fuse are:

- Shorted heatsink IGBT power transistor
- Shorted heatsink commutation diode
- Shorted load bank
- Operating braking module on a DC bus without inverters present. This is typically encountered in common bus systems when drives are removed from service. See Section 7 for more information.
- Crowbar circuit has activated. In this case, there has been a severe overtemperature or other fault.

### 5.3.4. FAN RUNS CONSTANTLY

The fan only runs when the braking module heatsink is hot. If the heatsink is above 110°F, then the fan runs until the heatsink cools to 80°F. If the ambient temperature is above 80°F, the fan may run continuously. A constantly running fan does not indicate a problem with the module.

### 5.3.5. FAN DOESN'T RUN

The fan only runs when the braking module heatsink is hot. If the heatsink is above 110°F, then the fan runs until the heatsink cools to 80°F.

If the fan never runs, even when the heatsink is hot or during heavy braking operation, the module may shutdown on heatsink over-temperature. This occurs at a heatsink temperature of 160°F. If for any reason the fan does not appear to be working properly, check the following:

- Input and output fuses on the fan transformer. These will be located on or around the fan transformer itself.
- Check fan for blockage. Clean if necessary.
- Check fan transformer primary voltage and ensure it is within tolerance for the control voltage input for that module.
- Replace fan.
- If fan still doesn't operate, the heatsink temperature switch may be faulty. Contact Bonitron for return for repair.

## 5.3.6. MODULE OVER-TEMP, OR MODULE SEEMS TOO HOT

It is normal for this module to produce heat. Temperatures of 150°F are not uncommon. If the module's fan is running, and the module is operating properly, it is within normal tolerances.

If you have the R5 option, check the contacts at TS1-16, 17. If the contacts are open, then the module is inhibited due to over-temperature. If the fan is not running, see Section 5.3.5 above for assistance.

If the fan is running, check to make sure the airflow through and around the module is unobstructed.

If the ambient temperature is high in the cabinet or installation area, the module may overheat. Make sure the environment is within the operating temperature requirements listed in the Table 2-5: Specifications.

## 5.3.7. DRIVE TRIPS ON OVERVOLTAGE

Make sure the DC+ and DC- connections are made directly to the drive system bus. They should not be connected to terminals dedicated to an internal transistor circuit, on the inverter.

- If the drive trips on overvoltage and the module is ready to operate, watch the "Active Braking" light on the front of the module. If it never illuminates, check the connections to the DC bus of the drive system. Check the DC Bus voltage and make sure the bus voltage at the braking module exceeds the Turn on Voltage of the module, i.e. 750VDC for a 460VAC nominal system. See Table 6-2.
- If the "Active Braking" light comes on, check to make sure that the module is sized properly for the system. If the resistance of the load bank is too large, not enough current will flow to allow for the braking energy to be dissipated. Check the system design to make sure the braking requirements are matched with the braking module capacity.

## 5.3.8. BRAKING LIGHT FLICKERS

- During motor deceleration, the braking LED may flicker if the braking cycle energy is low. This is normal.
- If the braking light flickers when the inverter is idle, this may indicate high voltage, excessive noise, or harmonics on the main system rectifier input AC voltage. Check the incoming AC line for these problems. Consult the project engineer for the appropriate corrective action.
- In rare instances, the module is installed on a system that has very little capacitance, or the inverters have been removed from the bus. This configuration can cause damage to the braking module. See Section 7 in this manual for more information.

## 5.3.9. BRAKING LIGHT STAYS ON ALL THE TIME

- System voltage is too high or high harmonic content is present. Check main system rectifier input AC voltage. Refer to the DC Turn On Level found in Table 6-2.
- Note: If the measured DC bus (in standby) is greater than the RMS line voltage\*1.414, then harmonic distortion may be raising the DC bus voltage above the measured RMS reading of a standard meter. Consult the project engineer for the appropriate corrective action.

- Setpoint too low. The DC Bus Setpoint pot on the main control board may have been tampered with. If this is a possibility, then the module needs to be sent in for recalibration.
- Wrong braking module installed. Check the module chassis sticker for the part number. Refer to Section 2 of this manual and verify the sticker information represents the correct part number for your application and voltage levels. Remove and replace as required.
- Main control board has gone bad. Module needs to be sent in for repair.

### **5.4. TECHNICAL HELP – BEFORE YOU CALL**

If technical help is required, please have the following information available when calling:

- Serial number of unit
- Name of original equipment supplier (if available)
- Record the line to line voltage on all 3 phases
- Record the DC Bus voltage immediately after the AC voltage
- Brief description of the application
- Drive and motor hp or kW
- kVA rating of power source
- Source configuration Wye/Delta and grounding

## 6. ENGINEERING DATA

### 6.1. RATINGS CHARTS

**Table 6-1: Standard Model Ratings**

PART NUMBER	VOLTAGE	PEAK KW	PEAK HP	CONTIN. WATTS	CHX	OHMS	BRAKING DUTY CYCLE	CONTIN. DUTY CYCLE
M3452-L2B-R030	230	4.7	6.3	400	B	30.0	20%	10%
M3452-L3B-R020	230	7.0	9.4	600	B	20.0	20%	10%
M3452-L3B-R030	230	4.7	6.3	600	B	30.0	20%	10%
M3452-L6B-R010	230	14.1	18.9	1200	B	10.0	20%	10%
M3452-L8C-R004	230	32.0	42.8	1600	C	4.4	10%	5%
M3452-L9C-R007	230	21.0	28.1	1800	C	6.7	20%	10%
M3452-L9C-R015	230	9.4	12.6	1800	C	15.0	40%	20%
M3452-H2B-R120	460	4.7	6.3	400	B	120.0	20%	10%
M3452-H3B-R075	460	7.5	10.1	600	B	75.0	20%	10%
M3452-H6B-R038	460	15.0	20.1	1200	B	37.5	20%	10%
M3452-H8C-R018	460	32.1	43.1	1600	C	17.5	10%	5%
M3452-H9C-R025	460	22.5	30.2	1800	C	25.0	20%	10%
M3452-H9C-R050	460	11.3	15.1	1800	C	50.0	30%	15%
M3452-H9C-R108	460	5.2	7.0	1800	C	108.0	60%	30%
M3452-C2B-R120	575	7.4	9.9	400	B	120.0	10%	5%
M3452-C3B-R105	575	8.4	11.3	600	B	105.0	15%	8%
M3452-C6B-R053	575	16.8	22.6	1200	B	52.5	20%	10%
M3452-C9C-R035	575	25.2	33.8	1800	C	35.0	20%	10%
M3452-C9C-R050	575	17.7	23.7	1800	C	50.0	20%	10%
M3452-C9C-R108	575	8.2	11.0	1800	C	108.0	60%	30%

### 6.2. TURN ON VOLTAGES

**Table 6-2: Turn-on Voltages**

VOLTAGE CODE	NOMINAL AC LINE VOLTAGE	DC TURN ON VOLTAGE	DC TURN OFF VOLTAGE
L	230	375	360
H	460	750	720
C	575	910	880

## 6.3. WATT LOSS

**Table 6-3: Watt Loss**

RESISTORS	MAXIMUM CONTINUOUS LOSSES
L2, H2, C2	400
L3, H3, C3	600
L6, H6, C6	1200
L8, H8, C8	1600
L9, H9, C9	1800

## 6.4. CERTIFICATIONS

All units, except the L8, H8, and C8 modules are UL listed under file number E204386.

## 6.5. UL 508A SHORT CIRCUIT CURRENT RATING

When braking transistors are used with Underwriters Laboratories listed or recognized drives, the short circuit current rating (SCCR) is determined by the SCCR rating of the attached drive.

## 6.6. FUSE/CIRCUIT BREAKER SIZING AND RATING

Each module comes equipped with its own internal DC bus fuse. ***If the fuse happens to fail, it is not recommended to replace the fuse and reapply power. Further damages could result.*** Consult Bonitron if this situation arises.

If you wish to place fuses in your DC link, coordinate the fuse size with the proper wire size used in your link as per local codes and regulations. Fast acting semiconductor type fuses should be used.

The maximum AC input current for all units is 1 amp.

## 6.7. DIMENSIONS AND MECHANICAL DRAWINGS

**Figure 6-1: Enclosure Dimensional Outline (Styles "B" & "C")**

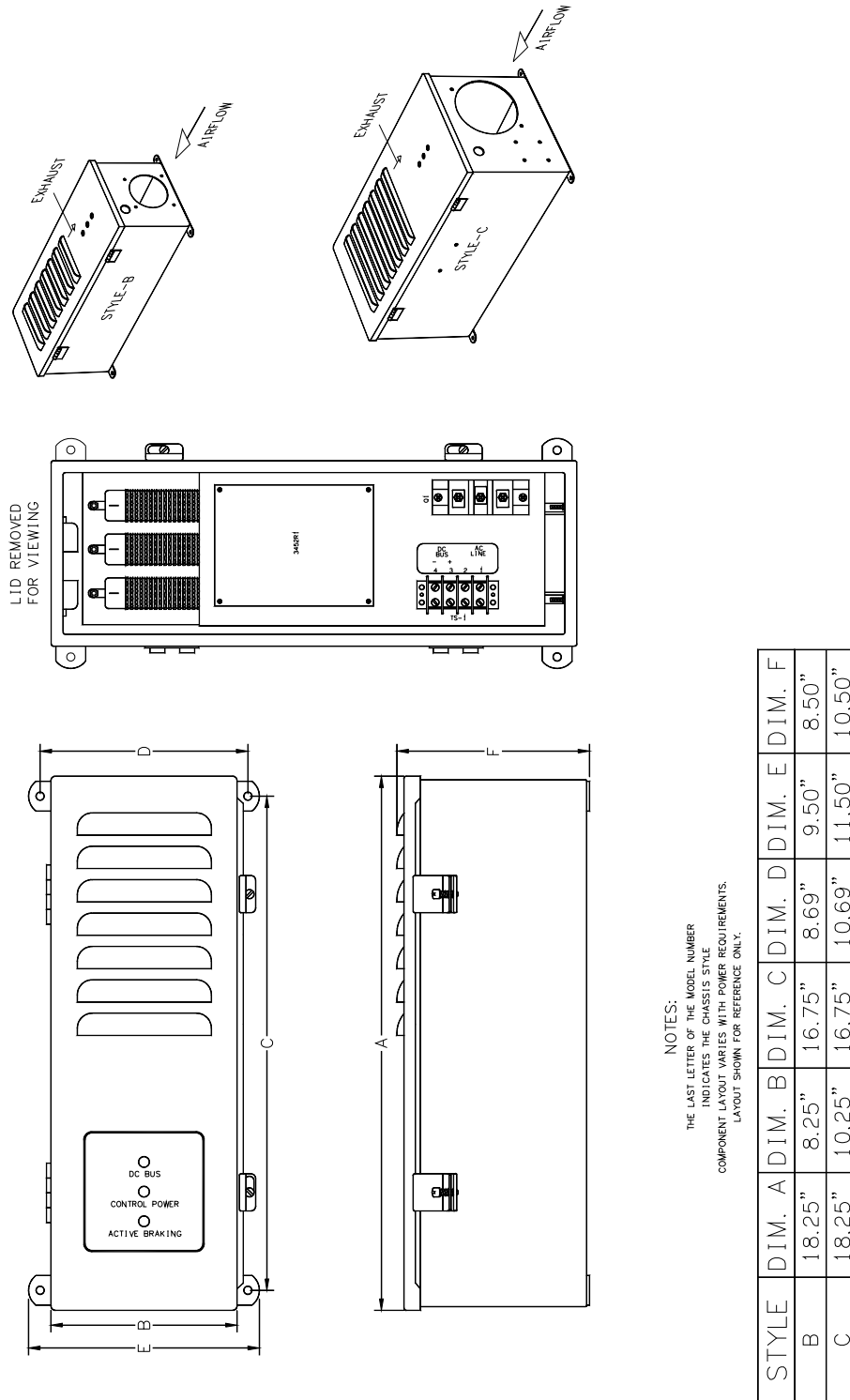

6.8. BLOCK DIAGRAMS

Figure 6-2: Block Diagram

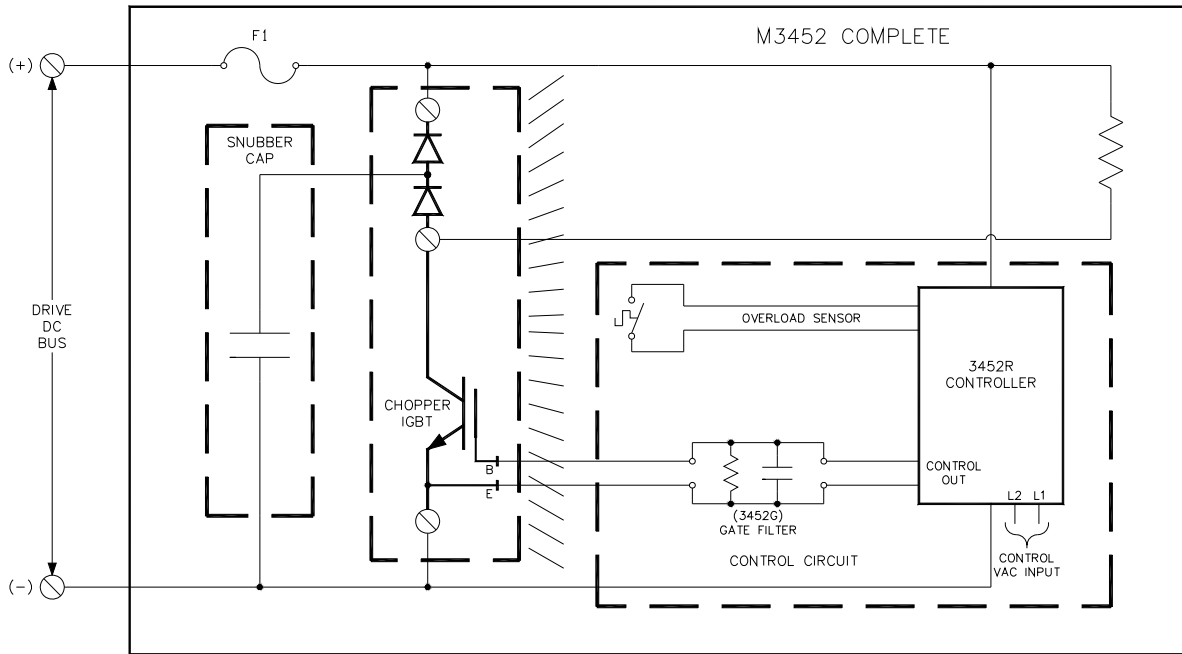

## 7. APPLICATION NOTES

### 7.1. SIZING YOUR BRAKING REQUIREMENTS

Braking Transistor Modules are sized by peak current requirements and system voltage. Please use the following guidelines:

- Verify the amount of peak power needed for braking. This must be determined from the mechanical system layout, and should be calculated in either peak watts or horsepower.
- VFD's are rated for braking power as well as peak braking capacity. This information is available in the drive manual. This will be the maximum amount of power that the output inverter stage of the VFD can absorb from the load before having an overcurrent condition. Refer to your VFD documents for information on drive sizing. Keep in mind that the current rating of the drive is for three phase current, not DC bus current. The braking current in the DC bus will be higher than the AC current absorbed from the load.
- Because Bonitron Braking Transistor Modules are rated for peak current, determine the *peak* braking power required.

#### 7.1.1. HORSEPOWER TO WATTS

Once the braking requirements for the mechanical load are determined, multiply the horsepower by the scaling factor of 746 to determine the wattage required. For instance, with a 400 hp system, the peak braking power may be 600 hp. In this case the peak power required would be:

$$P_{brake} = H.P. \cdot Braking * 746 \quad P_{brake} = 600 H.P. * 746 = 447600 \text{watts}$$

#### 7.1.2. PEAK AMPERAGE

The peak amperage of the braking cycle can be determined by dividing the peak braking wattage by the system bus trip point of the Braking Transistor Module used. If the above example were on a 480VAC system, the Turn on Voltage is 750VDC, as determined from Table 6-2. In this case the peak current required would be:

$$I_{brake} = P_{Braking} / 750VDC \quad I_{brake} = 447600 \text{watts} / 750VDC = 596.8 \text{ADC}$$

In this case, a 600 Amp module should be used.

#### 7.1.3. OHMIC VALUE

The ohmic value of the resistive load can usually be determined from Table 6-1: Standard Model Ratings. This ohmic value indicates the capacity of the braking transistor module, and may not be directly related to the horsepower of the drive. In order to calculate the required ohmic value for the braking load, use the following formula:

$$R_{brake} = \frac{(V_{DCbus})^2}{P_{brake}}$$

The DC bus voltage for the equation is determined by the level that the drive begins braking. For 460/480VAC systems, this is typically 750VDC, for 230VAC systems, it is typically 375VDC. Refer to your drive manual for specifics.

For the previous example, the ohmic value would be:

$$R_{brake} = (750VDC)^2 / 447600watts = 1.26ohms$$

This value must be verified with the ratings of the Braking Transistor Module selected that it is not less than the “minimum ohmic value” for that model. If so, the braking requirements may be more than the Braking Transistor Module can absorb, and a larger module may be required.

It is also possible to parallel two modules with two separate braking resistors to achieve the braking power required.

If the ohmic value calculated is greater than the value listed in the ratings table, it is possible to select a resistor value lower than the calculated value.

## 7.1.4. DUTY CYCLE

The duty cycle is based on the amount of time the drive is actually braking as opposed to accelerating, running at constant speed, or idle. For instance, if a pick and place operation requires 3 seconds to accelerate, traverses for 44 seconds and then decelerates for 3 seconds, the total cycle time is:

$$T_{cycle} = T_{acc} + T_{run} + T_{dec} = 3 + 44 + 3 = 50sec$$

The duty cycle for braking is:

$$\%_{duty} = T_{dec} / T_{cycle} = .06 = 6\%$$

This rating assumes the load will be linearly decreasing from peak braking power to zero braking as the load comes to a stop.

Check this rating against the modules duty cycle rating, and if it is higher than rated, go to the next higher rated module. If a duty cycle is required over 50%, please call for assistance with your application.

## 7.1.5. CONTINUOUS RATING

The continuous rating is listed for long term heating calculations should the unit be installed in an area where heat dissipation is an issue. The rating is based on a triangular cycle that starts at peak value and reduces to zero within the rated duty cycle. Therefore, the average braking power during the deceleration cycle is ½ the power required if full power was required during the entire braking cycle. This value is:

$$P_{continuous} = P_{peak} * \%_{duty} / 2$$

For the above example, the

$$P_{continuous} = 447600W * 6\% / 2 = 13428W$$

## 7.2. COMMON BUS APPLICATION NOTE

Bonitron Dynamic Braking Transistor Modules are designed to be compatible with individual stand-alone inverter/drive systems, or systems that incorporate a Common DC Bus arrangement. The Common DC Bus can be composed of multiple inverter/drive sections tied together where all or some of the sections use their respective AC input, or there may be a large independent Master DC Bus Supply feeding the DC inputs of all inverter/ drive sections. In the case of the large Master

DC Bus supply, it is common to find multiple rectifier sections in parallel to provide very high power levels. Some high power systems also include redundant or back up sections as well.

Once power is applied, all Bonitron modules are designed to be sourced from DC buses that have all the bus capacitors present.

Common DC Bus Systems composed of separate Master DC bus or rectifier sections have important imbedded differences. It is common to have a main distributed DC bus, and this is typically where the Dynamic Braking Transistor Modules connect. In this way, the Resistive Braking system is always present, even if some of the inverter/drive sections need to be removed from the bus for maintenance or other purposes. In emergency situations, it may even be necessary to “limp” along until repairs or swap outs can occur. Even though the modules are well suited for use in these systems, the following modes of operation could arise or exist and **are not allowed**:

1. **Do not** connect the Dynamic Braking Transistor Module on the rectifier side of a DC link choke. The connections must always be made to the inverter/drive side directly to the DC bus capacitors. During normal system operation, the choke can cause the braking system to begin ringing. This ringing causes high voltages that will damage the system.
2. **Do not** energize the system with no inverters/drives present on the distributed DC Bus.
3. **Do not** energize, operate, or run the system with less than 60% of the total expected system capacitance present.
4. Operating the modules in conditions 2 and 3 may make the modules respond to inbound line transients caused by SCR type rectifiers, powering up the system, or any number of other sources. Without sufficient DC bus capacitance, the DC bus will not be filtered, and can cause ringing that will produce high voltages that will damage the system.
5. In some drives, the pre-charge contactor may open under fault conditions, leaving the bulk system capacitance only resistively coupled to the Dynamic Braking Transistor Modules. Do not enable the modules in this situation. Review inverter/drive DC Bus pre-charge circuit operation with the drive manufacturer.

If there is the possibility of these situations:

- Open the enable input on the R7 or R7E options.
- Use a properly rated contactor in series with the modules' control voltage AC Input. The modules are effectively disabled when they do not have their control power.
- Keep the modules disabled during power up or any other time until all system capacitances are present.
- Disable the modules in the event system pre-charge contactors open.

Always consult Bonitron with any questions or concerns surrounding this topic.

### 7.3. BONITRON LINE REGENERATION MODULES

The Dynamic Braking Transistor Module is typically used in applications where infrequent regeneration occurs. When resistive braking is used, the regenerated energy is dissipated as heat. Dissipating this heat may be impractical in applications with more frequent regeneration. In these applications, the higher cost of the Bonitron M3345 Line Regen as compared with resistive braking is quickly offset

## M3452 Complete

---

because the regenerated energy, which is returned to the AC line with near unity power factor, can be used to power other equipment.



*This page intentionally left blank.*

---

---

