

Model M3528B
Battery Module

Customer Reference Manual

Bonitron, Inc.
Nashville, TN



An industry leader in providing solutions for AC drives.

ABOUT BONITRON

Bonitron designs and manufactures quality industrial electronics that improve the reliability of processes and variable frequency drives worldwide. With products in numerous industries, and an educated and experienced team of engineers, Bonitron has seen thousands of products engineered since 1962 and welcomes custom applications.

With engineering, production, and testing all in the same facility, Bonitron is able to ensure its products are of the utmost quality and ready to be applied to your application.

The Bonitron engineering team has the background and expertise necessary to design, develop, and manufacture the quality industrial electronic systems demanded in today's market. A strong academic background supported by continuing education is complemented by many years of hands-on field experience. A clear advantage Bonitron has over many competitors is combined on-site engineering labs and manufacturing facilities, which allows the engineering team to have immediate access to testing and manufacturing. This not only saves time during prototype development, but also is essential to providing only the highest quality products.

The sales and marketing teams work closely with engineering to provide up-to-date information and provide remarkable customer support to make sure you receive the best solution for your application. Thanks to this combination of quality products and superior customer support, Bonitron has products installed in critical applications worldwide.

AC DRIVE OPTIONS

In 1975, Bonitron began working with AC inverter drive specialists at synthetic fiber plants to develop speed control systems that could be interfaced with their plant process computers. Ever since, Bonitron has developed AC drive options that solve application issues associated with modern AC variable frequency drives and aid in reducing drive faults. Below is a sampling of Bonitron's current product offering.

WORLD CLASS PRODUCTS

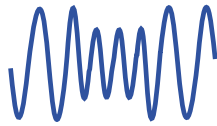

Undervoltage Solutions

Uninterruptible Power for Drives
(DC Bus Ride-Thru)
Voltage Regulators
Chargers and Dischargers
Energy Storage

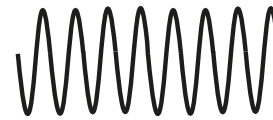

Power Quality Solutions

12 and 18 Pulse Kits
Filtering
Noise and Transient Suppression
Power Factor Correction

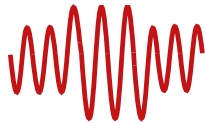

Overvoltage Solutions

Braking Transistors
Braking Resistors
Transistor/Resistor Combo
Line Regeneration
Dynamic Braking for Servo Drives

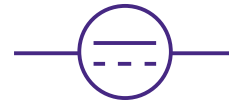

Common Bus Solutions

Single Phase Power Supplies
3-Phase Power Supplies
Common Bus Sharing Diodes
Isolation Diodes
Bus Filter Capacitance



Green/Sustainable Solutions

Voltage Boosters
(for Solar and Wind Applications)
Line Regeneration
Power Factor Correction



Portable Maintenance Solutions

Capacitor Formers
Battery Testers
Capacitor Testers
Capacitor Dischargers

1. INTRODUCTION.....	1
1.1. Who Should Use.....	1
1.2. Purpose and Scope.....	1
1.3. Manual Version and Change Record.....	1
Figure 1-1: Model M3528B.....	1
2. PRODUCT DESCRIPTION / FEATURES.....	3
2.1. Related Docs.....	3
2.2. Part Number Breakdown.....	4
Figure 2-1: Example of Part Number Breakdown.....	4
Table 2-1: Voltage Rating Codes.....	4
2.3. General Specifications Chart.....	5
Table 2-2: General Specifications Table.....	5
2.4. Precautions and Safety Warnings.....	6
2.4.1. VRLA Warnings and Precautions.....	6
2.4.2. Model M3528B Warnings and Precautions.....	10
3. INSTALLATION INSTRUCTIONS.....	11
3.1. Environment.....	11
3.2. Unpacking.....	12
3.3. Mounting.....	12
3.4. Wiring and Customer Connections.....	12
3.4.1. Power Wiring.....	12
Table 3-1: Field Wiring Connections.....	12
3.4.1.1. Source Considerations.....	12
3.4.1.2. Grounding Requirements.....	12
3.4.2. Control Wiring.....	12
Table 3-2: Control Wiring Connections.....	12
3.5. Typical Configurations.....	13
Figure 3-1: Typical DC Charger and Battery System Wiring.....	13
Figure 3-2: Typical DC Charger and Battery System Wiring with Dual Boosters.....	14
4. OPERATION.....	15
4.1. Functional Description.....	15
4.2. Features.....	15
4.2.1. Indicators.....	15
4.2.2. M3528M2 Battery Monitor Board Option.....	15
Figure 4-1: Typical Interconnection with Existing Drive System.....	16
4.3. Startup.....	17
4.3.1. Pre-Power Checks.....	17
4.3.2. Startup Procedure And Checks.....	17
4.3.3. Changing Battery Bank for Different System Voltages.....	17
4.3.3.1. To change from 120V to 108V for 208/415VAC systems:.....	17
4.3.3.2. To change from 108V to 120V for 230/460VAC systems:.....	18
5. MAINTENANCE AND TROUBLESHOOTING.....	19
5.1. Maintenance.....	19
5.1.1. Periodic Testing.....	19
5.1.2. Preparation for Storage.....	19
5.1.3. Module Removal and Replacement Procedures.....	20
5.2. Troubleshooting.....	20
5.3. Disposal of Battery Bank.....	20

6. ENGINEERING DATA.....	21
6.1. Ratings Charts.....	21
Table 6-1: M3528B Ratings Charts.....	21
Table 6-2: Constant Power Discharge Rate per Unit.....	21
Table 6-3: Typical Storage Bank Configurations.....	21
6.2. Fuse Rating.....	21
6.3. Dimensions and Mechanical Drawings.....	22
Figure 6-1: 108/120V 40A Battery Module Dimensional Outline.....	22
6.4. Supplemental Drawings.....	23
Figure 6-2: M3528B Battery Module Wiring with P2.....	23
6.5. Recommended Spare Parts.....	24
Table 6-4: Parts List for Model M3528B.....	24
7. APPENDIX.....	25
7.1. Application Notes.....	25
7.1.1. State of Charge.....	25
Table 7-1: State of Charge for Typical VRLA Batteries using 10.5V.....	25
7.1.2. Equalizing Battery Charge.....	26
7.2. Battery Life.....	26
7.2.1. Cyclic Service Life.....	26
7.2.2. Float Service Life.....	26
Figure 7-1: Discharge Cycles and Battery Life.....	27
Table 7-2: Temperature vs Battery Life.....	27
Figure 7-2: Temperature vs Battery Life Graph.....	28
7.3. VRLA Battery Maintenance Recommendations.....	28
Table 7-3: VRLA Battery Maintenance Recommendations.....	28

This page intentionally left blank.

1. INTRODUCTION

1.1. WHO SHOULD USE

This manual is intended for use by anyone who is responsible for integrating, installing, maintaining, troubleshooting, or using this equipment with any AC drive system.

Please keep this manual for future reference.

1.2. PURPOSE AND SCOPE

This manual is a user's guide for the Model M3528B. It will provide the user with the necessary information to successfully install, integrate, and use the M3528B in a M3534 system.

In the event of any conflict between this document and any publication and/or documentation related to the AC drive system, the latter shall have precedence.

1.3. MANUAL VERSION AND CHANGE RECORD

An Application Note regarding Equalizing Battery Charge was added in Rev 03d.

Rev 04 and 04a have updated rating information.

Life Cycle data was added to Section 7 in Rev 04b.

Drawings and layout were updated in Revs 04c and 04d.

Figure 1-1: Model M3528B



This page intentionally left blank.

2. PRODUCT DESCRIPTION / FEATURES

Model M3528B is a 108 or 120 VDC battery bank module designed to provide emergency power during 100% power outages for industrial applications. The M3528B Battery Module is commonly used along with the M3528 Charger and M3534 Ride-Thru Voltage Regulator as part of a complete Ride-Thru system for fixed bus variable frequency drives (VFDs).

VFDs are commonly used in industry to improve control over continuous process applications where accurate motor speed control is required. Unfortunately, these systems are susceptible to problems caused by fluctuations of incoming power, such as AC line voltage sags or outages. These power quality problems can be very costly for continuous process applications.

M3528 / 3534 systems are specifically designed to allow a drive system to maintain full motor speed and torque during a 100% loss of power, allowing the drive system to “ride through” the short term outage, or allowing sufficient time for auxiliary power systems to engage before shutdown occurs.

- Pluggable for easy and safer installation / replacement
- Fused to limit current
- LED blown fuse indication
- Easy mounting
- VRLA batteries for low maintenance and easy replacement
- Access for changing battery string voltage to optimize system

2.1. RELATED DOCS

M3528 CHARGER

M3528 is a voltage and current limited power supply used to charge electrical energy storage devices such as battery banks or ultracapacitors for industrial voltage levels of 208V - 480V. User inputs allow for remote enable and second setpoint charging for battery equalization.

M3534B OR M3460B

When used with a battery bank, such as the M3528B Battery Module, M3534B and M3460B Battery Voltage Regulators provide DC bus support during a power sag or outage.

M3528M2 VOLTAGE MONITOR

The M3528M2 Voltage Monitor is a separate monitor that measures the voltage across a string of storage modules, batteries or capacitors, and can give an indication to shut down a system when the storage string voltage drops too low to avoid premature aging of the storage string. It can also be used to indicate overvoltage on a storage string to avoid damage due to overcharging or other faults.

2.2. PART NUMBER BREAKDOWN

Figure 2-1: Example of Part Number Breakdown

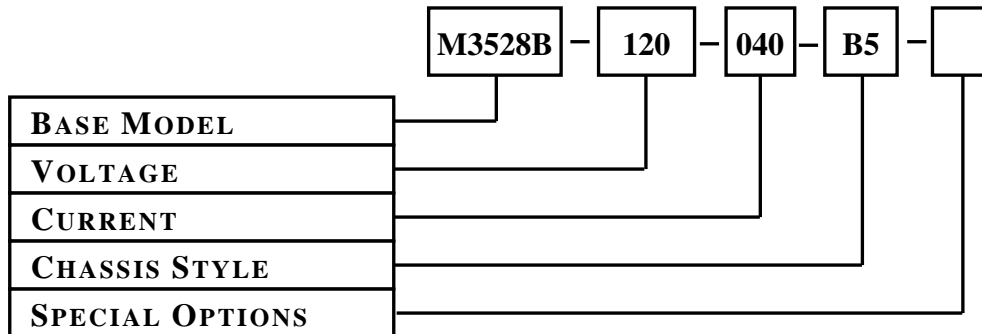

BASE MODEL NUMBER

The Base Model Number for all Battery Modules is M3528B.

VOLTAGE RATING

The Voltage Rating indicates the total series voltage for the battery bank and is indicated by a numeric code.

Table 2-1: Voltage Rating Codes

RATING CODE	DESIGNATION
108	9 series batteries for 208V or 415V systems
120	10 series batteries for 230V or 460V systems

CURRENT

This designation indicates the maximum current the batteries can output at the 30 second discharge rate.

CHASSIS

The Chassis Style and size is designated by an alphanumeric code. The B5 panel mount enclosure measures 17.60" (h) x 5.10" (w) x 9.40" (d).

SPECIAL OPTIONS

M = MONITORING OPTION

This designation indicates a monitoring PCB can be ordered that will indicate and give alarm if battery exceeds minimum or maximum voltage ratings. Output can be used to disable charging, or to allow for remote indication of battery module condition.

2.3. GENERAL SPECIFICATIONS CHART

Table 2-2: General Specifications Table

PARAMETER	SPECIFICATION
DC Output Voltage	108VDC or 120VDC
DC Output Current	40A maximum peak; 17A rms nominal
Power Rating	108V: 4.3kW peak; 1.8kW rms nominal 120V: 4.8kW peak; 2.0kW rms nominal
Storage Cells (ea. BSM)	(9) 12V, 4Ah for 108V (10) 12V, 4Ah for 120V Use CSB-GP-1245 or Yuasa NP4-12 or equivalent
Charge Current	1.25A DC maximum
Charge Times	Initial charge time of less than 4 hrs Recharge time depends on system requirements
Fuse	(1) A60Q40 – located on internal mounting plate
Enclosure	B5 panel mount enclosure 17.60”(h) x 5.10”(w) x 9.40”(d)
Optimum Operating Temp	25°C NOTE: Operation above 25°C degrades battery life by 50% for every 7°C above optimum. Operation below 25°C degrades capacity. See Section 7.1.2.
Discharge Temp	-20°C to +50°C
Charge Temp	0°C to +40°C
Storage Temp	25°C or less for 3 months without recharge
Overtemp Contact	N.C. contact opens at 110°F
Voltage Isolation	Power connector: 2500VAC to earth Temp sensor terminals: 1500VAC to earth
Battery Life Expectancy	1-3 years (or 300 cycles) if housed in environments above 30°C 3-5 years (or 500 cycles) if housed in environments below 30°C See Sections 2.3.1 and 7.1 for additional precautions and data
Humidity	Below 90 % non-condensing
Atmosphere	Free of corrosive gas and dust

2.4. PRECAUTIONS AND SAFETY WARNINGS

2.4.1. VRLA WARNINGS AND PRECAUTIONS

The following warnings and precautions are re-printed from the battery manufacturer for your convenience.

Before using the stationary valve regulated lead acid battery (called "the VRLA battery" hereafter), make sure you read its accompanying user's manual or precautionary notes carefully. Since VRLA batteries store energy, inappropriate usage can cause fluid leakage, heat generation, explosion, or bodily injury. If you do not fully understand our storage battery user manual or precautionary notes, please direct your questions to Bonitron.



- **VRLA BATTERIES MAY EMIT HYDROGEN GAS. ISOLATE BATTERIES FROM FIRE, SPARKS OR OTHER IGNITION SOURCES.**
- **STORE CHARGE AND OPERATE BATTERIES ONLY IN A WELL VENTILATED AREA OR ENCLOSURE. FAILURE TO DO SO CAN LEAD TO LEAD TO EXPLOSION, FIRE, EQUIPMENT DAMAGE AND BODILY INJURY.**
- **DO NOT SHORT THE POSITIVE TERMINAL AND NEGATIVE TERMINAL OF THE VRLA BATTERY WITH A WIRE OR OTHER METALS. IN ADDITION, MAKE SURE METAL TOOLS, SUCH AS SCREW DRIVERS, SPANNERS, TORQUE WRENCHES ARE PROPERLY INSULATED WITH VINYL MATERIALS BEFORE USING THEM WITH ONE OF OUR VRLA BATTERIES. SHORT CIRCUITING THE TERMINALS OF THE BATTERY CAN CAUSE BURN INJURIES, DAMAGE TO THE BATTERY, OR TRIGGER EXPLOSIONS.**
- **NEVER USE THE VRLA BATTERY WITH OTHER TYPES OF BATTERIES, SUCH AS ALKALINE, NiCAD OR NiMH BATTERIES.**
- **NEVER HEAVILY HIT OR IMPROPERLY CARRY THE BATTERY.**
- **NEVER SHORT THE TERMINALS.**
- **NEVER DISASSEMBLE THE BATTERY.**



- **BATTERIES CONTAIN SULFURIC ACID. IN CASE OF A RUPTURE OR LEAKAGE, FOLLOW THESE FIRST AID INSTRUCTIONS:**
 - **INHALATION:** REMOVE TO FRESH AIR. IF NOT BREATHING, GIVE ARTIFICIAL RESPIRATION. IF BREATHING IS DIFFICULT, GIVE OXYGEN. CALL A PHYSICIAN IMMEDIATELY.
 - **INGESTION:** DO NOT INDUCE VOMITING. GIVE LARGE QUANTITIES OF WATER. NEVER GIVE ANYTHING BY MOUTH TO AN UNCONSCIOUS PERSON. CALL A PHYSICIAN IMMEDIATELY.
 - **SKIN CONTACT:** IN CASE OF CONTACT, IMMEDIATELY FLUSH SKIN WITH PLENTY OF WATER FOR AT LEAST 15 MINUTES WHILE REMOVING CONTAMINATED CLOTHING AND SHOES. WASH CLOTHING BEFORE REUSE. EXCESS ACID ON SKIN CAN BE NEUTRALIZED WITH A 2% SOLUTION OF BICARBONATE OF SODA. CALL A PHYSICIAN IMMEDIATELY.
 - **EYE CONTACT:** IMMEDIATELY FLUSH EYES WITH GENTLE BUT LARGE STREAM OF WATER FOR AT LEAST 15 MINUTES, LIFTING LOWER AND UPPER EYELIDS OCCASIONALLY. CALL A PHYSICIAN IMMEDIATELY.



- **WHEN CHARGING THE VRLA BATTERY, USE A DEDICATED CHARGER AND FOLLOW OUR COMPANY'S CHARGING CONDITIONS. CHARGING UNDER DIFFERENT CONDITIONS CAN CAUSE THE BATTERY TO LEAK FLUID, OVERHEAT, OR EXPLODE.**
- **DO NOT IMMERSE OR USE THE VRLA BATTERY IN WET CONDITIONS. DOING SO CAN CAUSE THE BATTERY'S TERMINALS TO CORRODE, AND/OR CAUSE ELECTRICAL SHOCK OR FIRE.**
- **USE PROPER PROTECTION, SUCH AS VOLTAGE RATED LINEMAN'S GLOVES WHEN CONNECTING THE VRLA BATTERY IN A SERIES OF 45 VOLTS OR GREATER.**
- **MAKE SURE YOU CONNECT VRLA BATTERIES BY THEIR PROPER POLARITY. CONNECTING THE BATTERY IN THE WRONG POLARITY CAN CAUSE FIRE OR DAMAGE TO THE CHARGER.**
- **DO NOT INCINERATE OR DO NOT APPLY HEAT TO THE BATTERY. VRLA BATTERIES MAY BURST OR EXPLODE WHEN BURNED.**
- **DO NOT DISASSEMBLE, MODIFY OR DESTROY THE BATTERY. DOING SO CAN CAUSE FLUID LEAKAGE, HEAT GENERATION OR EXPLOSION.**
- **BEFORE CLEANING OR CHECKING THE VRLA BATTERY, MAKE SURE YOU RELEASE YOUR BODY'S STATIC ELECTRICITY BY TOUCHING A GROUNDED METAL OBJECT. DO NOT USE A DRY CLOTH OR DUSTER TO CLEAN THE STORAGE BATTERY. ALWAYS USE A CLOTH THAT CONTAINS AN ADEQUATE AMOUNT OF MOISTURE. SPARKS CREATED BY STATIC ELECTRICITY CAN CAUSE THE STORAGE BATTERY TO TRIGGER AN EXPLOSION.**
- **REPLACE THE VRLA BATTERY AT OR BEFORE THE TIME INDICATED IN THE USER'S MANUAL OR ON THE BATTERY. USAGE BEYOND THE REQUIRED TIME OF SERVICE CAN CAUSE FLUID LEAKAGE DUE TO DAMAGES TO THE CONTAINER, OR CAUSE FIRE DUE TO POWER LEAKAGE.**



- **THE PERFORMANCE OF THE VRLA BATTERY MAY NOT BE COMPATIBLE WITH CERTAIN EQUIPMENT. CONSULT WITH BONITRON IF THE SPECIFICATIONS ARE NOT WITHIN THE TOLERANCES LISTED IN THIS MANUAL.**
- **DO NOT USE THE BATTERY IF THERE IS ANY CORROSION, CRACKING, DEFORMATION, HEAT GENERATION, OR OTHER DEFECT. PLEASE CALL THE LOCATION WHERE IT WAS PURCHASED. USING THE BATTERY WITH A DEFECT CAN CAUSE THE BATTERY TO LEAK FLUID, GENERATE HEAT OR EXPLODE.**
- **STORE ALL BATTERIES BEYOND THE REACH OF CHILDREN. ALSO KEEP CHILDREN AND INFANTS AWAY WHEN CHARGING A VRLA STORAGE BATTERY.**
- **THE TEMPERATURE RANGES FOR USING VRLA BATTERIES ARE LISTED BELOW. USAGE OUTSIDE THE FOLLOWING TEMPERATURE RANGES CAN SHORTEN BATTERY LIFE, LOWER ITS PERFORMANCE LEVEL, CAUSE THE BATTERY TO LEAK FLUID, GET DAMAGED OR DEFORMED.**
 - **DISCHARGE: -20°C TO 50°C (DURING USE OF EQUIPMENT)**
 - **CHARGE: 0°C TO 40°C**
 - **STORAGE: -20°C TO 40°C**
- **DO NOT USE OR STORE VRLA BATTERY WHERE THE SURROUNDING TEMPERATURES EXCEED 50°C. DOING SO CAN SHORTEN BATTERY LIFE, LOWER ITS PERFORMANCE LEVEL, CAUSE THE BATTERY TO LEAK FLUID, GET DAMAGED OR DEFORMED.**
- **DO NOT LET THE VRLA BATTERY'S DISCHARGE CURRENT EXCEED THE MAXIMUM VALUE FOR THE DISCHARGE CURRENT LISTED IN ITS SPECIFICATIONS. EXCEEDING THE MAXIMUM VALUE FOR THE DISCHARGE CURRENT CAN CAUSE THE BATTERY TO LEAK FLUID, OVERHEAT OR EXPLODE.**
- **MAKE SURE YOU ALWAYS TURN OFF THE SWITCHES OR THE EQUIPMENT AFTER USE. ALSO MAKE SURE THE BATTERY IS REMOVED FROM THE EQUIPMENT WHENEVER THE EQUIPMENT IS GOING TO BE OUT OF USE FOR A PROLONGED PERIOD. EXCESS DISCHARGE OF THE BATTERY CAN LOWER ITS PERFORMANCE LEVEL, SHORTEN BATTERY LIFE OR OTHER DAMAGE.**

- **AFTER USING THE BATTERY (I.E., DISCHARGING), RECHARGE AS SOON AS POSSIBLE.**
- **WHEN THE BATTERY IS NOT TO BE USED FOR A LONG PERIOD, REMOVE THE INTERNAL FUSE AND STORE IN A COOL DRY PLACE.**

2.4.2. MODEL M3528B WARNINGS AND PRECAUTIONS



- **HIGH VOLTAGES ARE PRESENT! VOLTAGES DO NOT DRAIN ONCE POWER IS REMOVED!**
- **USE INSULATED SAFETY GLOVES AND STAND ON AN INSULATED SURFACE WHEN HANDLING BATTERY BANKS.**
- **NEVER ATTEMPT TO OPERATE THIS PRODUCT WITH THE ENCLOSURE COVER REMOVED.**
- **NEVER ATTEMPT TO SERVICE THIS PRODUCT WITHOUT FIRST DISCONNECTING POWER TO AND FROM THE UNIT.**
- **FAILURE TO HEED THESE WARNINGS MAY RESULT IN SERIOUS BODILY INJURY OR DEATH.**



- **CERTAIN COMPONENTS WITHIN THIS PRODUCT MAY GENERATE HIGH TEMPERATURES DURING OPERATION.**
- **ALWAYS ALLOW AMPLE TIME FOR THE UNIT TO COOL BEFORE ATTEMPTING SERVICE ON THIS PRODUCT.**
- **BEFORE ATTEMPTING INSTALLATION OR REMOVAL OF THIS PRODUCT, BE SURE TO REVIEW ALL AC DRIVE DOCUMENTATION FOR PERTINENT SAFETY PRECAUTIONS.**
- **INSTALLATION AND/OR REMOVAL OF THIS PRODUCT SHOULD ONLY BE ACCOMPLISHED BY A QUALIFIED ELECTRICIAN IN ACCORDANCE WITH NATIONAL ELECTRICAL CODE OR EQUIVALENT REGULATIONS.**

ANY QUESTIONS AS TO APPLICATION, INSTALLATION, OR SERVICE SAFETY SHOULD BE DIRECTED TO THE EQUIPMENT SUPPLIER.

3. INSTALLATION INSTRUCTIONS



Installation and/or removal of this product should only be performed by a qualified electrician in accordance with National Electrical Code or local codes and regulations.

Proper installation of the Model M3528B Battery Module should be accomplished following the steps outlined below. Be sure to refer to the AC Drive instruction manual as these steps are performed. Please direct all installation inquiries that may arise during the installation and start up of this product to the equipment supplier or system integrator.



Installation of battery bank safety notes:

- *Battery banks contain hazardous voltages and should be considered a live source of power.*
- *When battery plugs are inserted, insulated gloves should be used when handling plugs as voltage is always present on battery bank.*
- *Take care to stand on something insulated from earth ground or any return path in case of contact with battery voltage.*



Batteries are shipped with fuses removed!

- *Before putting the battery banks into service, the fuses must be installed properly.*
- *When fuses are inserted, insulated gloves should be used when handling as voltage is always present on battery bank.*
- *Take care to stand on something insulated from earth ground or any return path in case of contact with battery voltage.*
- *Always remove fuses before storage or decommissioning of battery banks.*

3.1. ENVIRONMENT

The installation site for the M3528B Battery Module should be chosen with the following considerations in mind:

- The unit has an open rating which will require some protection from the elements.
- The M3528B should be mounted in a vented enclosure to prevent build-up of gas.
- Heat is the enemy of any battery. Ensure inside temp of the enclosure remains around 77°F under steady state charging condition. Any increase in temperature will decrease battery life. See Section 7.1.2.
- Plug should be positioned at the top of the unit.
- Conduit access for field wiring is provided at the bottom of the enclosure.
- **THE UNIT IS HEAVY!** Mounting provisions must be capable of supporting at least 50 lbs.
- The unit will require a minimum clearance of two (2) inches in all directions around it when mounted near a non-heat source.
- The mounting surface should be clean and dry.

3.2. UNPACKING

Upon receipt of this product, please verify that the product received matches the product that was ordered and that there is no obvious physical damage to the unit. If the wrong product was received or the product is damaged in any way, please contact the supplier from which the product was purchased.

3.3. MOUNTING

Once the installation site has been selected as outlined above, the site should be prepared for installation of the unit. Mounting holes should be drilled and mounting studs or anchors installed at this time. **THE M3528B ENCLOSURE IS HEAVY, weighing approximately 50 lbs!** Mounting provisions installed must be capable of handling this weight! Mounting hardware is not supplied with the unit. Refer to 108/120V 40A Battery Module Dimensional Outline in Section 6.3 of this manual to determine the correct mounting dimensions and provisions for the unit.

Wiring conduit should be routed to the bottom right corner of the M3528B module. The unit is provided with a single removable cover for conduit access.

3.4. WIRING AND CUSTOMER CONNECTIONS

3.4.1. POWER WIRING

See Figure 6-1 for power terminal locations.

Table 3-1: Field Wiring Connections

TERMINAL	DESCRIPTION	WIRE SIZE	TORQUE
P1-1	DC+, positive battery terminal	12AWG	4.5 in/lbs (0.5 Nm)
P1-2	No Connection		
P1-3	No Connection		
P1-4	DC-, negative battery terminal	12AWG	4.5 in/lbs (0.5 Nm)

3.4.1.1. SOURCE CONSIDERATIONS

The M3528B Battery Module should be charged using a voltage and current limited charging device. The M3528 AC or DC charger would be suitable for this.

3.4.1.2. GROUNDING REQUIREMENTS

All units come equipped with either a ground terminal or ground stud that is connected to the module chassis. Ground the chassis in accordance with local codes.

3.4.2. CONTROL WIRING

Table 3-2: Control Wiring Connections

TERMINAL	DESCRIPTION	WIRE SIZE	TORQUE
P2-1	OT - A	18 AWG	9 in/lbs (1 Nm)
P2-2	OT - B	18 AWG	9 in/lbs (1 Nm)

See Figure 6-1 for Control Wiring Terminations.

3.5. TYPICAL CONFIGURATIONS

Figure 3-1: Typical DC Charger and Battery System Wiring

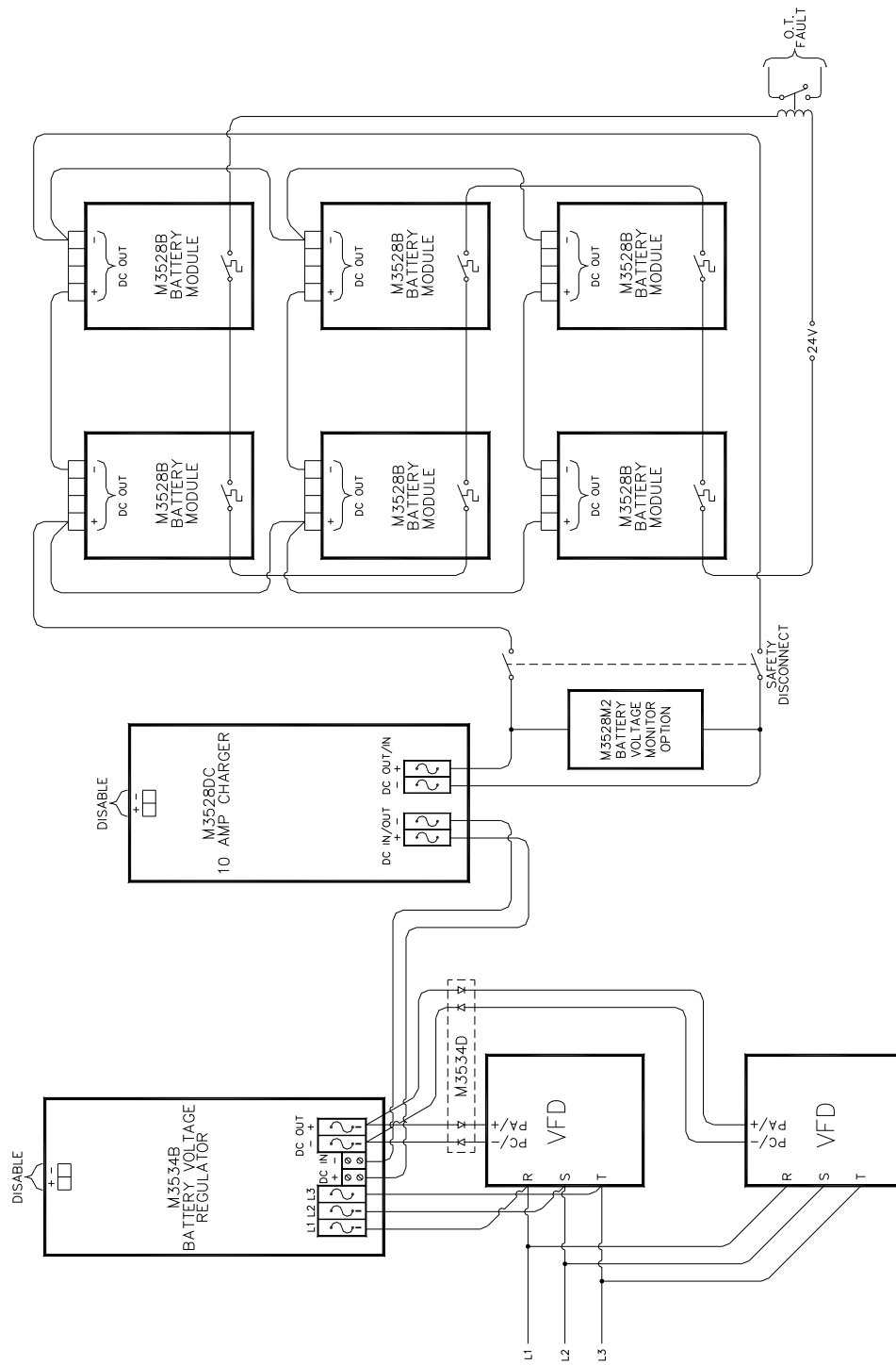
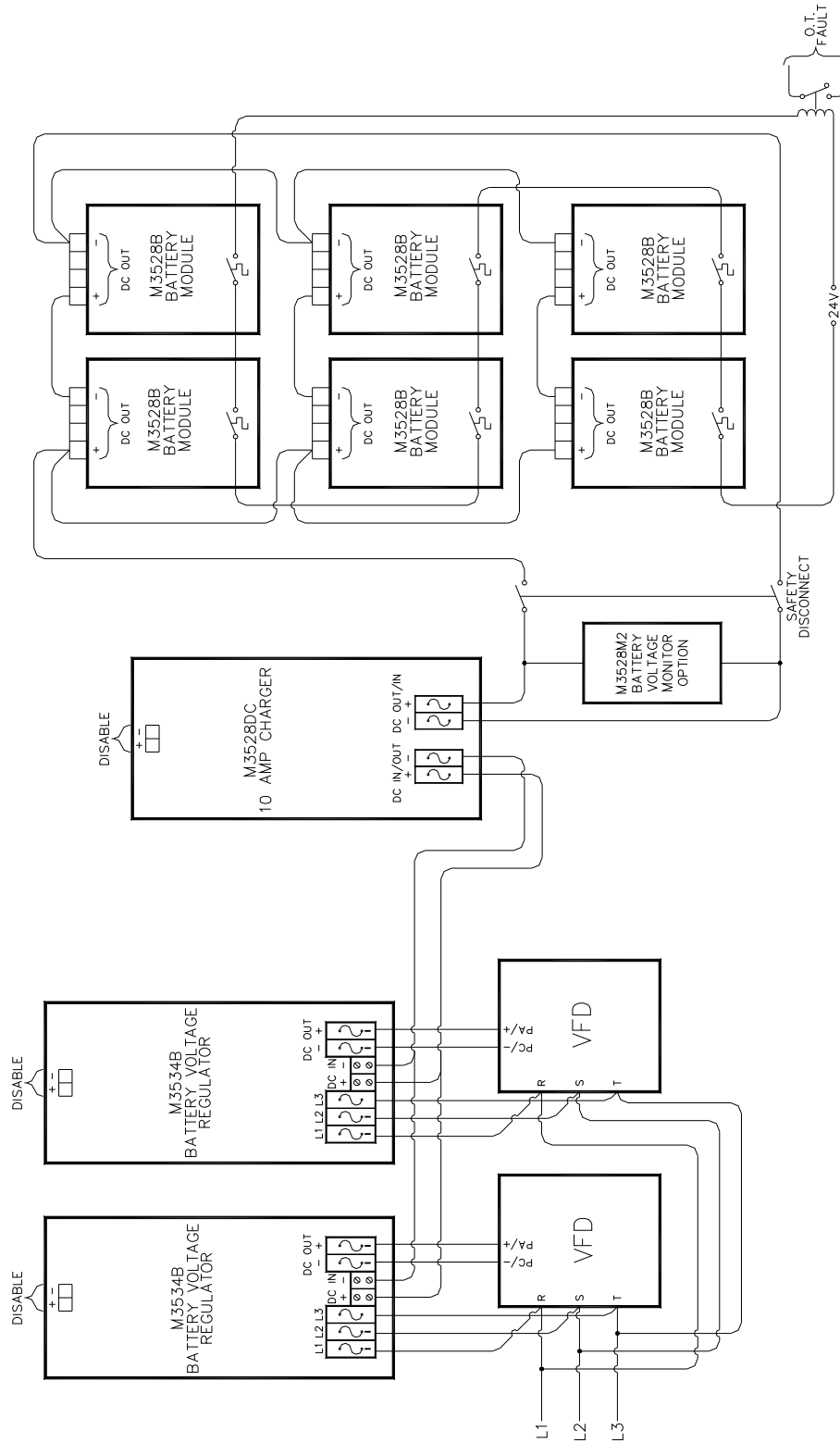

Figure 3-2: Typical DC Charger and Battery System Wiring with Dual Boosters



4. OPERATION

4.1. FUNCTIONAL DESCRIPTION

The M3528B Battery Modules are used for storage with the M3534 Ride-Thru Voltage Regulators for backing up for variable frequency drive systems. The battery modules can be configured in series strings to allow for higher storage voltages, or in parallel to allow for more energy storage and backup time.

A charger is required to maintain the voltage level on the battery string during standby. Refer to the M3528 Charger manual for details.

If the Battery Monitoring option is used the fault indicator will illuminate, and the fault can be determined from the indicator.

4.2. FEATURES

4.2.1. INDICATORS

BLOWN FUSE:

The Blown Fuse LED illuminates when fuse is blown and bank is either charging or discharging.

NOTE: The M3528B modules are shipped with the fuses removed. The fuses are located under the main cover, and must be installed prior to use.

4.2.2. M3528M2 BATTERY MONITOR BOARD OPTION

If Battery Monitoring was ordered as an option, please see the M3528M2 manual that accompanies the monitor.

Figure 4-1: Typical Interconnection with Existing Drive System

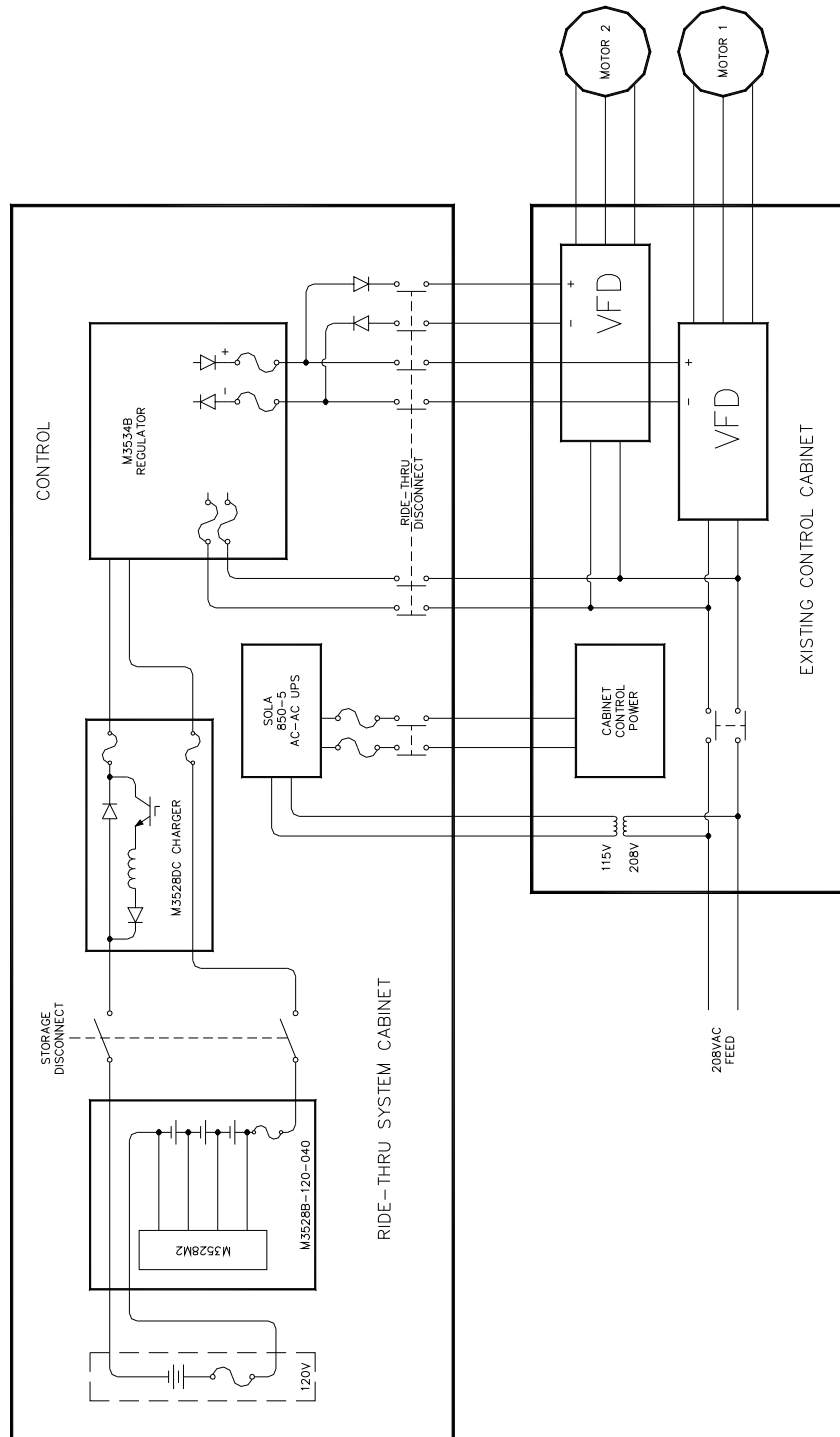

4.3. STARTUP

4.3.1. PRE-POWER CHECKS

The M3528B modules are shipped with the fuses removed. The fuses are located under the main cover, and must be installed prior to use. Refer to Figure 6-1 for fuse location.

Check the wiring to each and ensure proper polarity.



- *Improper connection due to improper polarity may cause batteries to overheat or rupture.*
- *Series strings of batteries can produce high voltages that can be lethal.*
- *Remove fuses before service to the battery module or battery string.*

4.3.2. STARTUP PROCEDURE AND CHECKS

Connect the power to and from the battery in accordance with system procedure.

Connecting the battery bank to a Ride-Thru system without main power applied may cause excessive precharge currents, and may blow the fuse or cause damage to the connected equipment.

4.3.3. CHANGING BATTERY BANK FOR DIFFERENT SYSTEM VOLTAGES



- *The battery banks are marked at the factory with the voltage set when shipped.*
- *If you change the battery voltage, MAKE SURE you indicate the new voltage on the battery string, as improper voltage may cause premature failure, overcharging, overheating and catastrophic failure!*
- *Use extreme caution when working on the battery connections. Shorting the batteries may cause arcing, battery failure, or fire.*

The nominal string voltage of the battery string is indicated in the part number.

In some configurations, the battery string voltage can be changed from 108VDC to 120VDC. In order to do so, remove the M3528B from service and follow the procedures below.

Refer to Figure 6-1 and Figure 6-2 for placement and wiring of batteries.

4.3.3.1. TO CHANGE FROM 120V TO 108V FOR 208/415VAC SYSTEMS:

1. Once the M3528B module has been removed from the cabinet, place the module on its left side, open side up, on a workbench.
2. Measure total series voltage with multimeter and note voltage. 120V bank will typically settle around 127VDC after being removed from the charger. (See Table 7-1)
3. Remove white wire (connected to fuse block) from battery "B1B" (+) terminal.
4. Disconnect jumper wire between "B1A" (+) and "B1B" (-), leaving one end of jumper on terminal of "B1B" (-), and tape up the other end of jumper using insulated electrical tape or equivalent.
5. Install white wire onto (+) terminal of "B1A".

6. Measure total series voltage with multimeter to confirm new voltage. 108V bank will typically measure 114VDC while unloaded in a charged state. (See Table 7-1)

4.3.3.2. TO CHANGE FROM 108V TO 120V FOR 230/460VAC SYSTEMS:

1. Once the M3528B module has been removed from the cabinet, place the module on its left side, open side up, on a workbench.
2. Measure total series voltage with multimeter and note voltage. 108V bank will typically settle around 114VDC after being removed from the charger. (See Table 7-1)
3. Remove white wire from battery "B1A" (+).
4. Remove insulating tape from jumper (if used) and reconnect jumper wire between "B1A" (+) and "B1B" (-).
5. Install white wire (connected to fuse block) onto terminal of "B1B" (+).
6. Measure total series voltage with multimeter to confirm new voltage. 120V bank will typically measure 127VDC while unloaded in a charged state. (See Table 7-1)

5. MAINTENANCE AND TROUBLESHOOTING

5.1. MAINTENANCE



- *Improper connection due to improper polarity may cause batteries to overheat or rupture.*
- *Series strings of batteries can produce high voltages that can be lethal.*
- *Remove fuses before service to the battery module or battery string.*

The M3528B Battery Modules use valve regulated lead acid (VRLA) battery technology. These batteries have an expected life of 500 complete discharge cycles or approximately 3 years under normal usage at 77°F. For this reason, it is necessary to replace batteries and modules periodically.

A battery life depends on two main factors: discharge cycles and ambient temperature. Based on your application, the replacement rate may be higher. Please see the Application Notes in Section 7 for more information.

5.1.1. PERIODIC TESTING

Each six months, the battery string should be tested and monitored for deterioration or failure. For critical applications, you may prefer to test them more frequently. Test the battery string by placing the string under 25% to 50% load for a few seconds and measure the terminal voltage of the battery string while under load. If the battery string voltage drops by more than 25% under load (see Table 7-1), insure that the battery string is fully charged, and then retest. Each module should be measured individually.

A no load test may be performed on the battery strings as well. Remove the plug from each module, and measure the open voltage between P1-1 and P1-4. If the open terminal voltage is 25% lower than the expected float voltage (see Table 7-1), fully charge the battery module, and retest.

Failure of either test can indicate that the battery has failed, or is close to failure.

5.1.2. PREPARATION FOR STORAGE

To prevent unnecessary battery drain during extended periods of storage, all M3528B Battery Modules are shipped with their external battery connectors unplugged and fuses removed.

Prior to storage or extended periods of disuse, remove the plugs and fuses from the modules to avoid unnecessary discharge.

If monitoring option is installed, remove plug to circuit board.

DO NOT store the batteries for periods longer than one week discharged. This can cause permanent damage to the batteries.

Store in a climate controlled dry location with proper ventilation. Temperatures above 77°F degrade battery life; below 77°F degrade battery capacity.

5.1.3. MODULE REMOVAL AND REPLACEMENT PROCEDURES

The following step-by-step procedure is intended to aid in the removal and replacement of an M3528B Battery Module.

1. Remove system power.
2. Disconnect all wired plug-in connectors from the battery module.
3. Remove the M3528B module from the cabinet.
4. Remove the cover from the M3528B and remove the internal fuse.

5.2. TROUBLESHOOTING

SYMPTOM	ACTION
No output voltage	<ul style="list-style-type: none"> • Check and replace fuse
Fault LED ON during charge cycle	<ul style="list-style-type: none"> • Check and replace fuse
Fault LED ON during discharge cycle	<ul style="list-style-type: none"> • Check and replace fuse
Low output voltage	<ul style="list-style-type: none"> • Check Table 6.3 for typical battery levels during operation. • Ensure load has not increased beyond battery capability. • If battery monitor is installed, load the battery bank and identify battery or batteries out of tolerance. Then replace the batteries. • If battery monitor not installed and the load is correct, replace the battery bank.

5.3. DISPOSAL OF BATTERY BANK

DO NOT dispose of these or any batteries in the common waste stream. VRLA batteries contain significant amounts of lead.

Federal and State laws prohibit improper disposal of VRLA batteries due to lead content. The battery end users (owners) are responsible for proper disposal.

All VRLA batteries must be recycled at a Resource Conservation and Recovery Act (RCRA) approved smelter or recycling center. Please contact your local waste disposal resources to determine where to dispose of your M3528B Battery Modules.

Various national recycling programs exist, including the Panasonic LEAD Recycling program. Call 1-800-SAV-LEAD for more information.

6. ENGINEERING DATA

6.1. RATINGS CHARTS

Table 6-1: M3528B Ratings Charts

MODEL #	BANK VOLTAGE	FLOAT CHARGE VOLTAGE	MIN. DISCHARGE VOLTAGE	SYSTEM AC VOLTAGE
M3528B-108-040-B5	108	121	90	208
M3528B-120-040-B5	120	135	100	230/460

Table 6-2: Constant Power Discharge Rate per Unit

Model #	BANK VOLTAGE		30 SECONDS		1 MINUTE		2 MINUTES		4 MINUTES	
	Start	End	Watts	Joules	Watts	Joules	Watts	Joules	Watts	Joules
M3528B-120-040-B5	135	100	3,000	90,000	2,500	150,000	2,000	240,000	1,500	360,000
M3528B-108-040-B5	121	90	2,700	81,000	2,250	135,000	1,800	216,000	1,350	324,000

Table 6-3: Typical Storage Bank Configurations

Not to replace manufacturer's recommendations.

		SYSTEM AC VOLTAGE	208	230	400	460
Battery Bank	Nominal Voltage		216	240	420	480
	108VDC banks in series		2	0	4	0
	120VDC banks in series		0	2	0	4
	Full or Float Charge Voltage		243	270	473	540
	Equalize Voltage		249	277	484	554
	Discharged Voltage		180	200	350	400
M3534R	Threshold		265	285	485	585

6.2. FUSE RATING

Each module has an integral 40 amp fuse. When replacing, use a Ferraz A60Q40 or equivalent.

6.3. DIMENSIONS AND MECHANICAL DRAWINGS

Figure 6-1: 108/120V 40A Battery Module Dimensional Outline

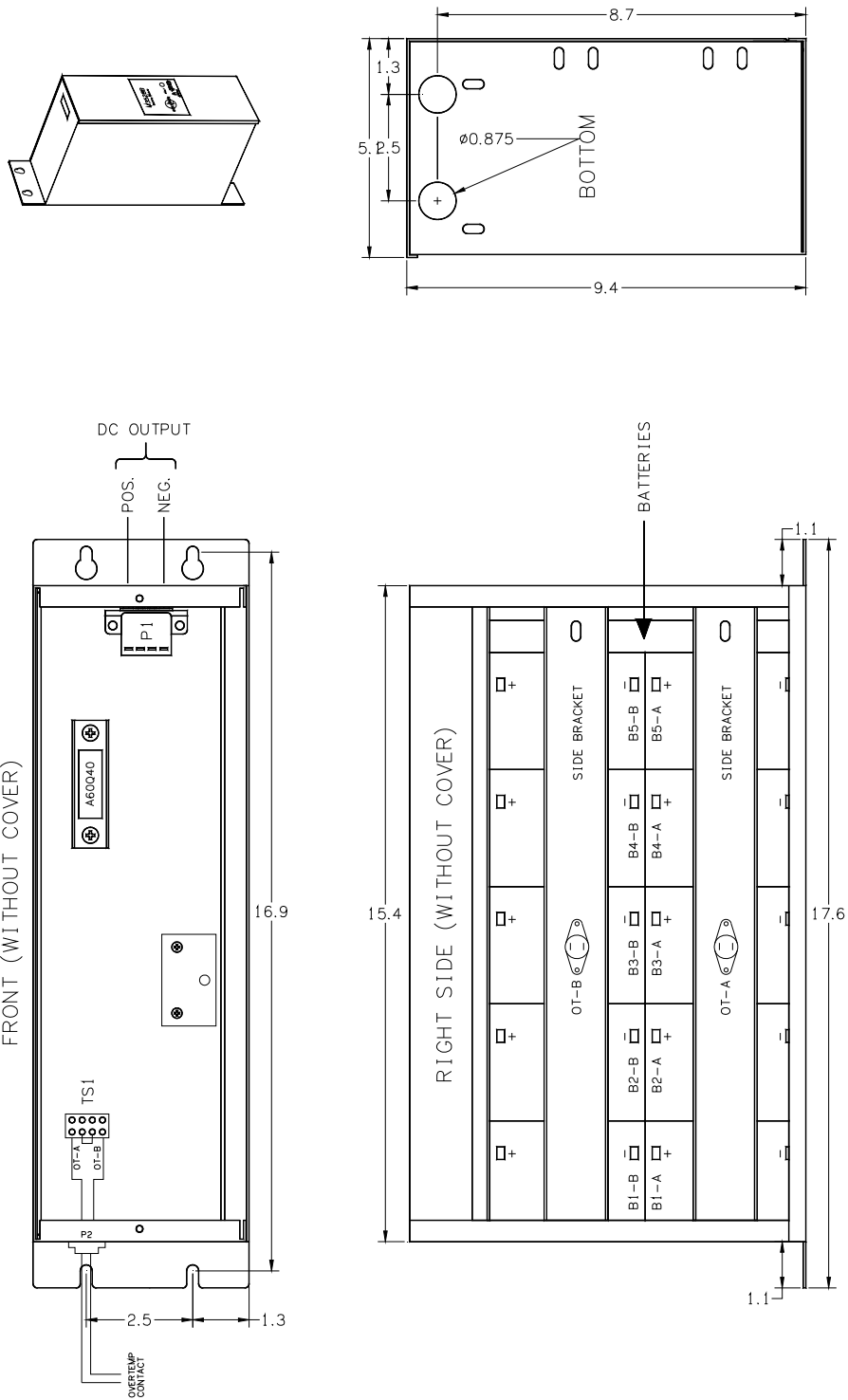

6.4. SUPPLEMENTAL DRAWINGS

Figure 6-2: M3528B Battery Module Wiring with P2

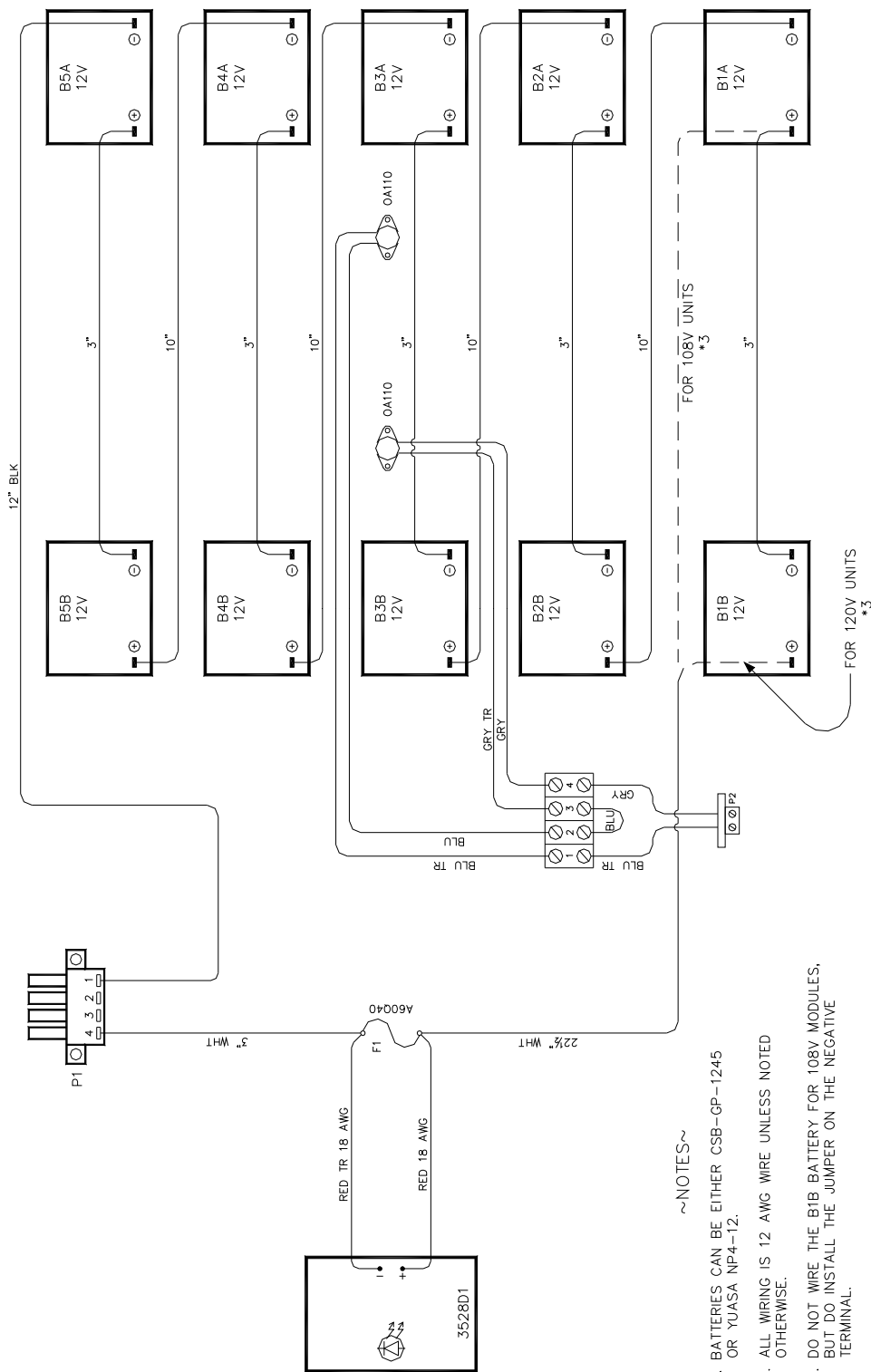

6.5. RECOMMENDED SPARE PARTS

Table 6-4: Parts List for Model M3528B

PART NUMBER	DESCRIPTION	QTY
FS A60Q40	DC link fuse	1

7. APPENDIX

7.1. APPLICATION NOTES

- It is important to use the proper battery bank and threshold settings for the incoming AC line voltage of the system. Using a 230V battery system on a 208V line will likely cause unnecessary use of the battery bank, which will cause premature failure. The battery bank will run for approximately 500 cycles or last for 3-5 years if kept at optimum conditions.
- Make sure the charge voltage for the system is set properly as per the total string voltage. The M3528 series of chargers come preset with a charge voltage that is typical for the DC Bus storage float voltage for that nominal system voltage, however, verify these voltages at startup to insure there is no overcharging.
- Overcharging causes the batteries to produce large amounts of hydrogen gas that can build up and cause an explosion. It also causes overheating, battery electrolyte loss, and premature failure.
- Keeping the batteries in a medium temperature environment will increase their life span. See Section 7.1.2.
- The battery bank should be checked upon installation to ensure it is not supplying current during normal operation of the ride though system with power applied. Changing battery voltage and threshold can ensure proper operation.
- A disconnect switch between the battery bank and charger is recommended for safety during maintenance on charger or booster. Battery bank plugs can be used, but are not as safe as a switch. When using a disconnect, special care must be taken to NOT power up the charger from the battery bank as this may cause fuses to blow in the DC links between the charger and battery, as well as between the charger and booster. Charger should be powered up first, then the battery disconnect can be safely closed.

7.1.1. STATE OF CHARGE

An indication for state of charge is the “at rest” battery voltage. Table 7-1 shows a general guideline for typical at rest voltages and an approximate percentage of energy left. This table is not inclusive of all battery types and is meant only for general information on the basic tendencies of batteries.

Table 7-1: State of Charge for Typical VRLA Batteries using 10.5V

STATE OF CHARGE	12 VOLT BATTERY	108 VOLT BATTERY BANK	120 VOLT BATTERY BANK	VOLTS PER CELL
100%	12.7	114.30	127.00	2.12
90%	12.5	112.50	125.00	2.08
80%	12.42	111.78	124.20	2.07
70%	12.32	110.88	123.20	2.05
60%	12.20	109.80	122.00	2.03
50%	12.06	108.54	120.60	2.01
40%	11.9	107.10	119.00	1.98
30%	11.75	105.75	117.50	1.96
20%	11.58	104.22	115.80	1.93
10%	11.31	101.79	113.10	1.89
0	10.5	94.50	105.00	1.75

7.1.2. EQUALIZING BATTERY CHARGE

Using 12V batteries in series to make up higher voltage strings is common for UPS manufacturers providing products for 230/460VAC systems. One problem associated with many batteries in series is that after many complete charge / discharge cycles they can begin to have unequal charges, resulting in decreased performance of the whole string.

Under normal conditions it is not necessary to equalize the charge on a VRLA battery. An equalize charge is given only when a non conformity in voltage has developed between cells, and its purpose is to restore all series cells to a fully charged condition.

The absolutely best way to restore full charge to all batteries is to individually charge each battery to the bulk charge level and then allow time for absorption, but for a series string of 40 batteries this is not practical and would be time consuming.

The most practical way to restore charge in a series battery system is to go through an "Equalize Cycle". This cycle provides an increase in charging voltage for a specified time, which will add more charge to the lowest voltage cells, thus equalizing the bank. Typically the equalize cycle raises the string voltage by 2.5-5% for a few hours depending on battery manufacturers recommendations. Bonitron chargers are set on the low side of this range for 2.5% increase over set charging voltage.

7.2. BATTERY LIFE

7.2.1. CYCLIC SERVICE LIFE

There are a number of factors that will affect the length of cyclic service of a battery. The most significant are ambient operating temperature, discharge rate, depth of discharge, and the manner in which the battery is recharged. Generally speaking, the most important factor is depth of discharge. Figure xx illustrates the effects of depth of discharge on cyclic life.

The relationship between the number of cycles which can be expected, and the depth of discharge is readily apparent. In relation to a specified discharge rate, if the application requires a longer cyclic life than is obtainable by selecting the battery capacity according to common practice, select a battery with larger capacity. Thus, at the specified discharge rate over the specified time, the depth of discharge will be shallower and cyclic service life will be longer.

7.2.2. FLOAT SERVICE LIFE

The batteries are designed to operate in standby (float) service for approximately 3 years, based upon a normal service condition in which float charge voltage is maintained between 2.25 and 2.30 volts per cell in an ambient temperature of approximately 25°C (77°F). In normal float service, where charging voltage is maintained 2.25 to 2.30 volts per cell, the gases generated inside the battery cells are continually recombined, and return to the water content of the electrolyte. Therefore, electrical capacity is not lost due to "drying up" of the electrolyte. Through the gradual and very slow corrosion of the electrodes, the battery will eventually lose capacity and come to the end of service life. It should be noted that the corrosive process

will be accelerated by high ambient operating temperatures and/or high charging voltage. When designing a float service system, always consider the following:

Length of service life will be directly affected by the number of discharge cycles, depth of discharge, ambient temperature, and charging voltage.

Refer to the following charts for more information.

Figure 7-1: Discharge Cycles and Battery Life

TESTING CONDITIONS: DISCHARGE CURRENT: 0.17C AMP. (F.V. 1.7V/CELL)
 CHARGING CURRENT: 0.09C AMP.
 CHARGING VOLUME: 125% OF DISCHARGED CAPACITY
 AMBIENT TEMPERATURE: 20°C TO 25°C (68°F TO 77°F)

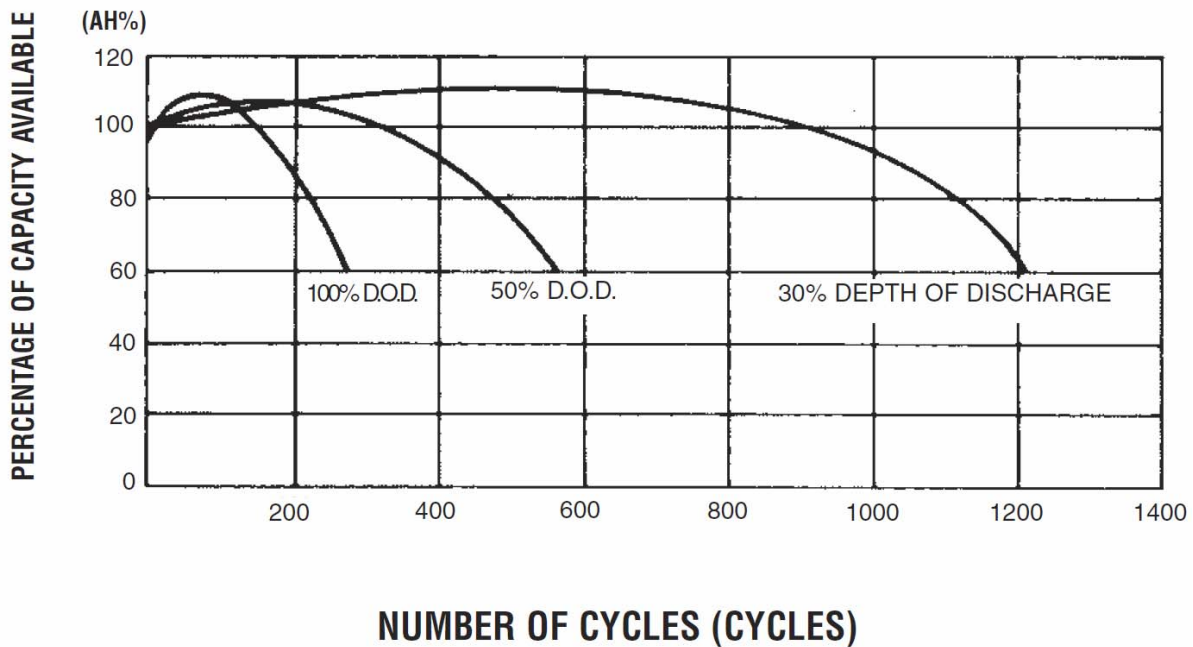
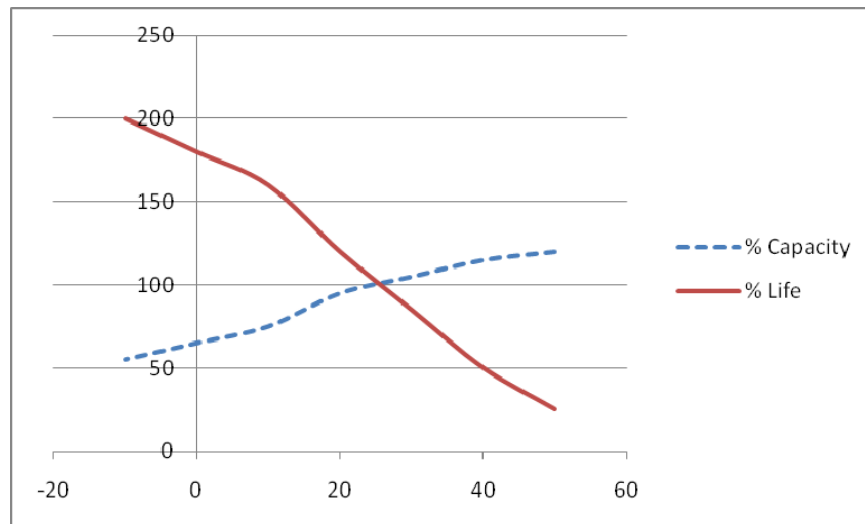

Table 7-2: Temperature vs Battery Life

Temp °C	Temp °F	% Life	% Capacity
50	122	25	120
40	104	50	115
30	86	85	105
20	68	120	95
10	50	160	75
0	32	180	65
-10	14	200	55

Figure 7-2: Temperature vs Battery Life Graph



7.3. VRLA BATTERY MAINTENANCE RECOMMENDATIONS

This is a general recommendation. Always follow the specific Battery manufacturers' recommendation if available.

Table 7-3: VRLA Batter Maintenance Recommendations

	MONTHLY	QUARTERLY	ANNUAL
Measure and record battery voltage	✓	✓	✓
Measure and record charger output current and voltage	✓	✓	✓
Measure and record ambient temp	✓	✓	✓
Inspect battery, rack, cabinet and area	✓	✓	✓
Inspect cells/units for cracks, leakage, and jar/cover distortion	✓	✓	✓
Inspect for evidence of corrosion at the terminals, connections, rack or cabinet	✓	✓	✓
Measure and record the voltage of each cell/unit		✓	✓
Measure and record the internal resistance cell /unit		✓	✓
Measure and record the negative post temperature of each cell /unit		✓	✓
Measure and record connection resistance cell/unit		✓	✓
For applications with a discharge rate of 1 hour or less measure and record a sample of connection resistances (min. of 10% or 6 connections)		✓	✓
Measure and record 100% of connection resistances			✓
Measure and record torque values of each connection			✓
Record date of cleaning and inspection	✓	✓	✓
Provide inspection report	✓	✓	✓

This page intentionally left blank.

This page intentionally left blank.
