

Model M3628R
Model M3628T
Ultracapacitor Discharge Controller
and Battery Bank Tester

Customer Reference Manual

Bonitron, Inc.
Nashville, TN



An industry leader in providing solutions for AC drives.

ABOUT BONITRON

Bonitron designs and manufactures quality industrial electronics that improve the reliability of processes and variable frequency drives worldwide. With products in numerous industries, and an educated and experienced team of engineers, Bonitron has seen thousands of products engineered since 1962 and welcomes custom applications.

With engineering, production, and testing all in the same facility, Bonitron is able to ensure its products are of the utmost quality and ready to be applied to your application.

The Bonitron engineering team has the background and expertise necessary to design, develop, and manufacture the quality industrial electronic systems demanded in today's market. A strong academic background supported by continuing education is complemented by many years of hands-on field experience. A clear advantage Bonitron has over many competitors is combined on-site engineering labs and manufacturing facilities, which allows the engineering team to have immediate access to testing and manufacturing. This not only saves time during prototype development, but also is essential to providing only the highest quality products.

The sales and marketing teams work closely with engineering to provide up-to-date information and provide remarkable customer support to make sure you receive the best solution for your application. Thanks to this combination of quality products and superior customer support, Bonitron has products installed in critical applications worldwide.

AC DRIVE OPTIONS

In 1975, Bonitron began working with AC inverter drive specialists at synthetic fiber plants to develop speed control systems that could be interfaced with their plant process computers. Ever since, Bonitron has developed AC drive options that solve application issues associated with modern AC variable frequency drives and aid in reducing drive faults. Below is a sampling of Bonitron's current product offering.

WORLD CLASS PRODUCTS

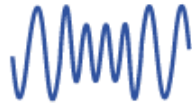

Undervoltage Solutions

Uninterruptable Power for Drives
(DC Bus Ride-Thru)
Voltage Regulators
Chargers and Dischargers
Energy Storage



Power Quality Solutions

12 and 18 Pulse Kits
Filtering
Noise and Transient Suppression
Power Factor Correction

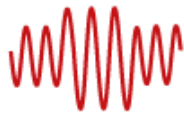

Overvoltage Solutions

Braking Transistors
Braking Resistors
Transistor/Resistor Combo
Line Regeneration
Dynamic Braking for Servo Drives



Common Bus Solutions

Single Phase Power Supplies
3-Phase Power Supplies
Common Bus Sharing Diodes
Isolation Diodes
Bus Filter Capacitance



Green/Sustainable Solutions

Voltage Boosters
(for Solar and Wind Applications)
Line Regeneration
Power Factor Correction



Portable Maintenance Solutions

Capacitor Formers
Battery Testers
Capacitor Testers
Capacitor Dischargers

| | |
|---|-----------|
| 1. INTRODUCTION | 1 |
| 1.1. Who Should Use | 1 |
| 1.2. Purpose and Scope | 1 |
| 1.3. Manual Version and Change Record | 1 |
| Figure 1-1: M3628T | 1 |
| 2. PRODUCT OVERVIEW | 3 |
| 2.1. Product Description | 3 |
| 2.1.1. M3628 Features | 3 |
| 2.2. Related Products | 4 |
| 2.2.1. Bonitron M3528 Charge Systems | 4 |
| 2.3. Part Number Breakdown | 4 |
| Figure 2-1: Example of Part Number Breakdown for M3628R | 4 |
| Figure 2-2: Example of Part Number Breakdown for M3628T | 5 |
| Table 2-1: Component Codes | 5 |
| Table 2-2: System Voltage Ratings for M3628T | 5 |
| 2.4. General Specifications | 6 |
| Table 2-3: General Specifications for M3628R Models | 6 |
| Table 2-4: General Specifications for M3628T Models | 6 |
| 2.5. General Precautions and Safety Warnings | 7 |
| 3. INSTALLATION INSTRUCTIONS | 9 |
| 3.1. Environment | 9 |
| 3.2. Unpacking | 9 |
| 3.3. Mounting | 9 |
| 3.4. Wiring and Customer Connections | 9 |
| 3.4.1. Power Wiring | 9 |
| Table 3-1: Chart of Power Terminals for the M3628T | 10 |
| 3.4.2. Control Interface Wiring | 10 |
| Table 3-2: Chart of Control Terminals for the M3628T | 10 |
| Table 3-3: ENABLE Logic Table | 11 |
| Figure 3-1: Typical Terminal Layout for 75A thru 300A Units | 12 |
| Figure 3-2: Typical Terminal Layout for 600A Units | 12 |
| Figure 3-3: PCB 3628D2 | 13 |
| Figure 3-4: Temperature Sensor Placement | 13 |
| Figure 3-5: M3628 System Control Interface Wiring | 14 |
| 3.5. Typical Configuration | 15 |
| Figure 3-6: Ride-Thru System Configuration 1 | 15 |
| Figure 3-7: Ride-Thru System Configuration 2 | 15 |
| Figure 3-8: 100% Outage Ride-Thru System Without Booster | 16 |
| 4. OPERATION | 17 |
| 4.1. Functional Description | 17 |
| 4.2. Features | 17 |
| 4.2.1. Indicators | 17 |
| 4.2.2. Bus Voltage | 17 |
| 4.2.3. 24V Supply | 17 |
| 4.2.4. Discharge Switch PCB Jumpers | 18 |
| 4.3. Startup | 18 |
| 4.3.1. Pre-power checks | 18 |
| 4.3.2. Startup Procedure | 18 |
| 4.3.3. Discharge Procedure | 18 |

| | | |
|-----------|---|-----------|
| 4.4. | No Operational Adjustments | 19 |
| 4.5. | Calibration | 19 |
| 5. | MAINTENANCE AND TROUBLESHOOTING..... | 21 |
| 5.1. | Periodic Testing..... | 21 |
| 5.2. | Maintenance Items..... | 21 |
| 5.3. | Troubleshooting..... | 21 |
| 5.3.1. | Unit will not discharge storage reservoir | 21 |
| 5.3.2. | Unit will not allow storage reservoir to charge..... | 21 |
| 5.3.3. | No DC POWER LED | 21 |
| 5.3.4. | No ENABLE LED | 21 |
| 5.3.5. | No ACTIVE LED | 22 |
| 5.3.6. | Over-Temp..... | 22 |
| 6. | ENGINEERING DATA..... | 23 |
| 6.1. | Ratings Charts | 23 |
| | Table 6-1: Typical Discharge Packages for 230VAC Systems..... | 23 |
| | Table 6-2: Typical Discharge Packages for 400VAC Systems..... | 24 |
| | Table 6-3: Typical Discharge Packages for 460VAC Systems..... | 25 |
| | Table 6-4: Typical Discharge Packages for 600VAC Systems..... | 26 |
| 6.2. | Watt Loss..... | 27 |
| | Table 6-5: Watt Loss During a Single Discharge Cycle | 27 |
| 6.3. | Fuse/Circuit Breaker Sizing and Rating | 27 |
| | Table 6-6: Recommended Fuse Range | 27 |
| 6.4. | Dimensions and Mechanical Drawings | 28 |
| | Figure 6-1: M3628T Chassis Dimensional Outline Drawing..... | 28 |
| | Table 6-7: M3628T Chassis Dimensions | 28 |
| | Figure 6-2: M3628R Dimensional Outline | 29 |
| | Table 6-8: M3628R Chassis Dimensions..... | 29 |
| 6.5. | Block Diagrams | 30 |
| | Figure 6-3: 75-600A Fast Discharge Basic Schematic | 30 |
| 7. | APPENDIX..... | 31 |
| 7.1. | Application Notes | 31 |
| 7.1.1. | Control Schemes | 31 |
| 7.1.2. | How to Figure RMS Current for capacitor Bank Discharge..... | 31 |
| 7.1.3. | Discharger Fusing Application Note | 32 |
| 7.1.4. | How to Choose a Discharge Switch and Resistor..... | 32 |
| | Figure 7-1: Discharge Resistor Selection Chart..... | 34 |

This page intentionally left blank

1. INTRODUCTION

1.1. WHO SHOULD USE

This manual is intended for use by anyone who is responsible for integrating, installing, maintaining, troubleshooting, or using this equipment with any Capacitive Energy Storage System.

Please keep this manual for future reference.

1.2. PURPOSE AND SCOPE

This manual is a user's guide for the Model M3628. It will provide the user with the necessary information to successfully install, integrate, and use the M3628 in a Capacitive Energy Storage System.

In the event of any conflict between this document and any publication and/or documentation related to the Capacitive Energy Storage System, the latter shall have precedence.

1.3. MANUAL VERSION AND CHANGE RECORD

Terminology, drawings, and company pages were updated.

Figure 1-1: M3628T



This page intentionally left blank

2. PRODUCT OVERVIEW

Ultracapacitors are now taking the place of batteries as the preferred method of storing energy for some industrial applications that experience short term power outages. When used with a Bonitron Voltage boost regulator up to 75% of the capacitors stored energy can be utilized. Specifications of 100ms, 500ms, and 2 seconds are now common for industrial motor control applications, and are a perfect fit for the amounts of energy stored in ultracapacitors.

One major advantage Ultracaps have over batteries is that the energy can be completely drained for safer maintenance and shipping. The trouble is that the caps contain so much energy it could take as long as a week to self discharge a capacitor bank. It is for this purpose Bonitron developed the M3628 IGBT switch and resistor packages.

Standard packages are based on joules and peak voltage, and are designed to discharge the capacitor bank to below 50V in 1 minute.

Automatic discharge can be set up using an aux contact on the cabinet disconnect switch or breaker, or manual discharge can be triggered locally or remotely via PLC control.

M3628T is Listed and M3628R is Recognized under UL508C standards for use with ultracapacitors.

2.1. PRODUCT DESCRIPTION

M3628T is an IGBT discharge switch for any system using electrolytic or ultracapacitor storage bank up to 800VDC, and is available between 75 and 600 Amps in a single package. Units may be paralleled for faster discharge times or larger energy banks.

M3628R is a pre-engineered discharge resistor bank designed to complement the IGBT switch modules and typical ultracapacitor bank voltage levels for 230/600VAC industrial systems. All are rated in joules & ohms with an 800VDC max. Units may be paralleled for faster discharge times or for larger energy banks.

2.1.1. M3628 FEATURES

- UL listed (for use with ultracapacitors)
- Ensures safety of maintenance crews
- Optically isolated remote discharge command
- Jumper selectable logic state
- Over-temp feedback contact for shut down
- Ability to abort drain cycle
- Self powered
- LED indicators
- Small footprint
- Matched resistor banks

2.2. RELATED PRODUCTS

2.2.1. BONITRON M3528 CHARGE SYSTEMS

Bonitron Model 3528 Charger is designed to charge Ultracapacitor or Battery DC energy storage banks up to 600V. M3528 provides a constant charge current until the storage bank reaches max voltage set-point. Once maximum voltage is reached, the charger enters voltage control mode cuts charge current back to maintain bank voltage, keeping it at optimum state and ready for use. Charging current is adjustable between 2 - 10 amps for 10 Amp, or 4 - 20 amps for 20 Amp, while maximum voltage is adjustable between 300 and 600VDC. Charging and discharging can be automatic or externally PLC controlled.

M3528 FEATURES

- Maximizes capacitor life
- Automatic charging, discharging
- Current limiting
- Voltage limiting
- LED indicators
- Small footprint
- Remote monitoring contacts
- Remote Enable and Equalize functions
- Wide voltage setpoint range
- Internal fuses

CONCLUSION:

To make best use of high voltage ultracapacitor products, an electronic controller (M3528) should be used to control charge and limit voltage level to caps.

To make the system safe for maintenance, an electronic discharger (M3628) is needed to bring the capacitor bank voltage down below 50V in a reasonable time period.

To better leverage capacitor storage energy making a complete ultracapacitor system less expensive and smaller in size, adding a voltage boost regulator (M3534 or M3460) should be considered.

2.3. PART NUMBER BREAKDOWN

Figure 2-1: Example of Part Number Breakdown for M3628R

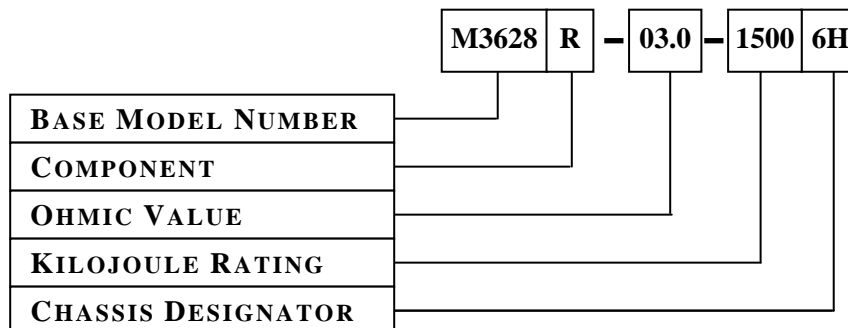
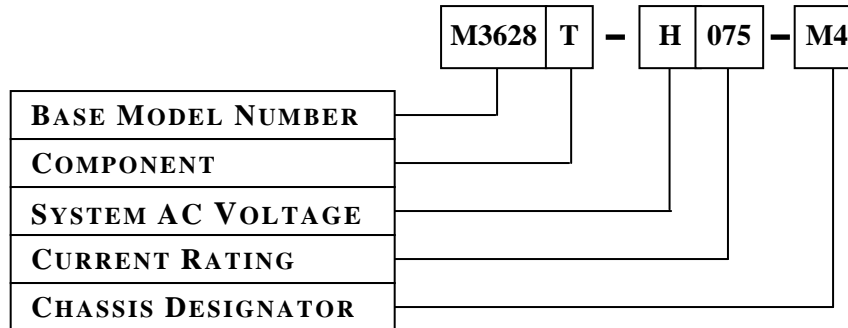

Figure 2-2: Example of Part Number Breakdown for M3628T



BASE MODEL NUMBER

The Base Model Number for all M3628 Discharge Controllers is **M3628**.

COMPONENT

Table 2-1: Component Codes

| COMPONENT | DESCRIPTION |
|-----------|-------------|
| R | Resistor |
| T | IGBT Switch |

SYSTEM AC VOLTAGE RATING

The System AC Voltage Rating indicates the maximum capacitor bank voltages for the M3628T. Voltage is indicated by a code letter.

Table 2-2: System Voltage Ratings for M3628T

| RATING CODE | AC SYSTEM VOLTAGE |
|-------------|-------------------|
| L | 208 - 277VAC |
| H | 380 - 600VAC |

OHM AND KILOJOULE RATINGS

The Ohmic Value and Kilojoule Rating are only applicable when ordering resistors (M3628R). The corresponding 2 or 3 digit rating is entered directly into the part number. **Example:** *M3628R-03.0-1500*

CURRENT RATING

The Current Rating is represented by a 3 digit code. i.e. the Current Rating Code for a 75 Amp unit would be 075. The Current Rating is only applicable when ordering transistors (M3628T). **Example:** *M3628T-H075*

CHASSIS CODE

See Section 6-4 for Chassis Codes and Dimensions.

2.4. GENERAL SPECIFICATIONS

Table 2-3: General Specifications for M3628R Models

| PARAMETER | SPECIFICATION |
|-----------------------------|---|
| System AC Voltage | Capacitor banks for 208 – 600VAC systems |
| Capacitor Bank Voltage | 800VDC maximum |
| joules | 350kjoules to 4mjoules |
| Duty Cycle | 1 discharge @ rated joules every 60 minutes with no forced air, or 1% duty cycle @ full voltage |
| Voltage Isolation | 2300VAC between element and chassis |
| Cooling | Customer supplied – for cabinet heating concerns |
| Storage Temperature Range | -50° to +100°C |
| Operating Temperature Range | 0° to +40°C |
| Humidity | 95% non-condensing |
| Altitude | Below 3000 ft |

Table 2-4: General Specifications for M3628T Models

| PARAMETER | SPECIFICATION |
|-----------------------------|---|
| System AC Voltage | Capacitor banks for 208 – 600VAC systems |
| Capacitor Bank Voltage | 800VDC maximum |
| Peak Current | See Tables 6-1 through 6-4. |
| RMS Current | 29% of Peak Rating for 5 minute discharge cycle |
| Continuous Current | 10% of Peak Rating |
| Duty Cycle | 3 discharges @ rated joules every 30 minutes with no forced air, or 5% duty cycle @ full current |
| Internal Control Voltage | Derived from capacitor bus |
| 24V Output | 20 – 24V @ 30mA max load |
| External Control Voltage | 22 – 26VDC @50mA |
| Voltage Isolation | 2300VAC between Power and Control or Chassis |
| I/O | Isolated Enable Input: 22 – 26VDC to start, < 1V to stop Current Limited Meter Output: 0-1mA meter with 800V scale Isolated Over Temperature: N.C externally mounted near resistor Isolated 24V supply for local ENABLE and OT |
| Cooling | Customer supplied – for cabinet heating concerns |
| Storage Temperature Range | -20°C to +65°C |
| Operating Temperature Range | 0°C to +40°C |
| Humidity | 95% non condensing |
| Altitude | Below 3000 ft |

2.5. GENERAL PRECAUTIONS AND SAFETY WARNINGS



DANGER!

- **HIGH VOLTAGES MAY BE PRESENT!**
- **NEVER ATTEMPT TO OPERATE THIS PRODUCT WITH THE ENCLOSURE COVER REMOVED!**
- **NEVER ATTEMPT TO SERVICE THIS PRODUCT WITHOUT FIRST DISCONNECTING POWER TO AND FROM THE UNIT!**
- **FAILURE TO HEED THESE WARNINGS MAY RESULT IN SERIOUS BODILY INJURY OR DEATH!**



CAUTION!

- **BEFORE ATTEMPTING INSTALLATION OR REMOVAL OF THIS PRODUCT, BE SURE TO REVIEW ALL DRIVE AND/OR RESISTIVE LOAD DOCUMENTATION FOR PERTINENT SAFETY PRECAUTIONS.**
- **INSTALLATION AND/OR REMOVAL OF THIS PRODUCT SHOULD ONLY BE ACCOMPLISHED BY A QUALIFIED ELECTRICIAN IN ACCORDANCE WITH NATIONAL ELECTRICAL CODE OR EQUIVALENT REGULATIONS.**

ANY QUESTIONS AS TO APPLICATION, INSTALLATION OR SERVICE SAFETY SHOULD BE DIRECTED TO THE EQUIPMENT SUPPLIER.

This page intentionally left blank

3. INSTALLATION INSTRUCTIONS

3.1. ENVIRONMENT

- M3628T (IGBT Switch) module must be mounted in cabinet.
- M3628R (Resistor) may be externally mounted, if fused.
- See Section 6.2 for Watt Loss information.

3.2. UNPACKING

- Inspect shipping crate for physical damage.
- Notify shipping carrier if damage is found.
- Remove terminal access plates to prepare for mounting.
- Inspect interior of unit for damage.

3.3. MOUNTING

IGBT Switch module (M3628T) should be mounted such that this is less than 10 feet of wire for each connection to the capacitor bank with a clearance of 2" on each side. Twist or tie the wires together to minimize inductance.

The resistor (M3628R) should be mounted within 16' of the M3628T with a clearance of 4" on each side with NO equipment mounted above the resistor.

- Resistor can be mounted vertically on cabinet backplate with wire connections on the bottom.
- Resistor can be mounted on top of cabinet with wire connections through conduit on the side.
- Supplied 220°F temperature sensor should be mounted on top of the resistor.
- Connection wires should not be above the resistor elements.

Refer to Section 6.5 for mounting and dimension information.

3.4. WIRING AND CUSTOMER CONNECTIONS

3.4.1. POWER WIRING

Isolation – All Power inputs have 2300VAC isolation from earth ground and Control connections.

See Figures 3-1, 3-2 and 3-4 for terminal layouts.

Capacitor input connections are located at the left side of power terminals, TS1-2 (+) , and TS1-3 (-). Wiring between capacitor bank and discharge switch should not be longer than 10 feet for each positive and negative leg (20 ft total) when using the maximum recommended wire size in Table 3-1. Wire may be sized for the rms current of a single discharge. See Table 3-1 for wire sizes and torques, and Tables 6-1 through 6-4 for switch peak and rms current ratings.

Resistor output connections are located at the right side of the power terminals, TS1-4 (+) and TS1-5 (-). Wiring between resistor and IGBT switch should not be longer than 16 feet for each positive and negative leg (32 ft total) when using the maximum recommended wire size in Table 3-1. Wire size should be equal to that of the capacitor input. See Table 3-1 for wire sizes and torques, and Tables 6-1 through 6-4 for recommended resistors.

The earth ground connection terminal is located to the left of the power terminals for the 75, 150, and 300 amp models, and for the 600 amp model

a stud is located to the left of the power terminals. See Table 3-1 for ground wire sizes and torques.

MTR (METER)

Output is a 0-1mA drive isolated by 300k ohms between each positive and negative DC capacitor bus rail. This is factory set for 1mA at 800VDC, and may require fine tuning depending on the meter used.

Table 3-1: Chart of Power Terminals for the M3628T

| SIGNAL | 75 AMP MODEL | | 150 AMP MODEL | | 300 AMP MODEL | | 600 AMP MODEL | |
|--------|---------------|--------------|---------------|--------------|---------------|--------------|---------------|--------------|
| | WIRE SIZE AWG | TORQUE LB-IN | WIRE SIZE AWG | TORQUE LB-IN | WIRE SIZE AWG | TORQUE LB-IN | WIRE SIZE AWG | TORQUE LB-IN |
| Cap | 12 - 8 | 7.1 – 14.2 | 8 - 2 | 35.4 – 44.3 | 6 - 2 | 35.4 – 44.3 | 14 – 2/0 | 120 |
| Res | 12 - 8 | 7.1 – 14.2 | 8 - 2 | 35.4 – 44.3 | 6 - 2 | 35.4 – 44.3 | 14 – 2/0 | 120 |
| Earth | 22 - 10 | 4.4 – 7.1 | 10 - 6 | 4.4 – 8.8 | 10 - 6 | 4.4 – 8.8 | 14 – 2/0 | 120 |
| Meter | 22 - 12 | 3.5 – 5.3 | 22 - 12 | 3.5 – 5.3 | 22 - 12 | 3.5 – 5.3 | 22 - 12 | 3.5 – 5.3 |

3.4.1.1. SOURCE CONSIDERATIONS

- Typical source for a M3628 system is an Ultracapacitor bank.
- M3628 systems are sized with the goal of draining the ultracapacitor bank below 50V in 1 minute.
- 3628R Models are sized to voltage and joule rating of Ultracapacitor bank.
- M3628T Models are sized to voltage and joule rating of capacitor bank, and peak current drain from resistor at max capacitor bank voltage.
- Power wiring does not need to carry continuous peak current rating. RMS current of 1 discharge cycle is roughly figured to be 29% of peak current.

3.4.1.2. GROUNDING REQUIREMENTS

Earth Ground provided for shielding control signals.

3.4.2. CONTROL INTERFACE WIRING

Isolation – All Control inputs have 2300VAC isolation from earth ground and Power connections.

External connections are provided for at the bottom of each unit at TS1 terminals. See Figures 3-1, 3-2 and 3-4 for terminal layout.

Table 3-2: Chart of Control Terminals for the M3628T

| SIGNAL | TS1 TERMINALS | ALL MODELS | |
|---------|---------------|---------------|--------------|
| | | WIRE SIZE AWG | TORQUE LB-IN |
| OT | 8 & 9 | 22 - 12 | 3.5 – 5.3 |
| 24V in | 10 & 11 | | |
| 24V out | 12 & 13 | | |
| EN | 14 & 15 | | |

OT (OVER-TEMPERATURE)

OT input should be 24V when temperature is OK. If using an internal 24V supply, connect as shown in Figure 3-4.

The Temp Sensor should be a N.C. switch. PCB jumper J2 OFF allows external temperature control. Its purpose is to protect the cabinet from damaging temperatures due to constant discharge in case of accidental ENABLE, or excessive cycling. Its temperature rating depends on physical placement inside the cabinet and is chosen by the cabinet designations. The wires connecting this sensor should be kept clear from “noisy” wire runs or equipment to prevent unwanted shutdown or enabling. If discharge resistors are supplied by Bonitron, a normally closed 220°F temperature sensor will be included and should be mounted on top of the resistor bank chassis as shown in Figure 3-4.

EN (ENABLE)

An external enable signal is used to control the IGBT switch state. This is an optically coupled input and can be set up for normal or inverted operation. See Table 3-2 for set up. Units are shipped in Automatic discharge mode which uses J1 in the B or INV position, so that when the 24V enable is removed by the cabinet disconnect switch, the capacitor bank discharges.

24V (OUTPUT SOURCE)

This 24V output is isolated from the drive system and may be earth grounded. It is meant to be used for a local enable command and connected to the 24V enable input via an aux contact on the cabinet door disconnect switch so that when the cabinet is turned off the caps are automatically discharged.

When using the internal power supply derived from the capacitor bus, this 24V out will begin to drop when the capacitor bank drops below 24V.

24V (INPUT)

This 24V input is isolated from the capacitor bank potential and can be used to power the IGBT switch module. The advantage of using an external 24V is that the capacitor bank can be held in the discharge state constantly in order to fully discharge to zero volts.

Table 3-3: ENABLE Logic Table

| ENABLE INPUT | J1 POSITION | OUTPUT IGBT SWITCH |
|---------------------|--------------------|---------------------------|
| High – On | A – Normal | ON |
| Low – Off | A – Normal | OFF |
| High - On | B – Inverted | OFF |
| Low – Off | B – Inverted | ON |

Figure 3-1: Typical Terminal Layout for 75A thru 300A Units

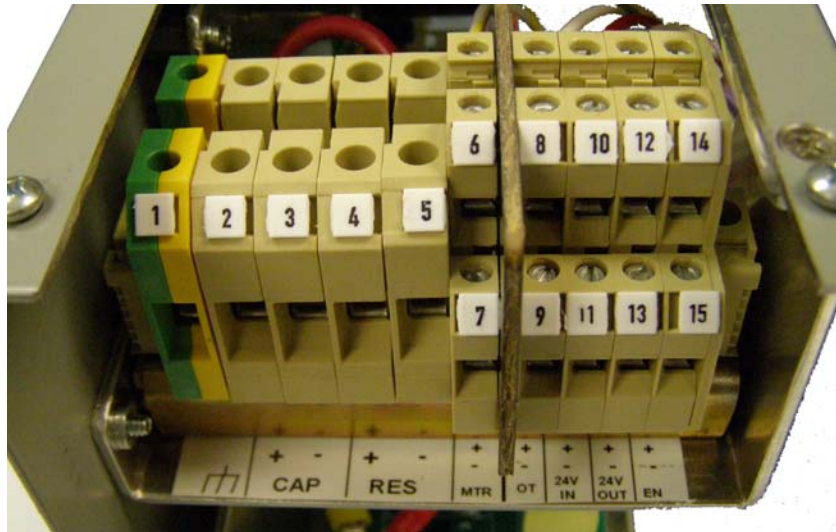

Figure 3-2: Typical Terminal Layout for 600A Units



Figure 3-3: PCB 3628D2

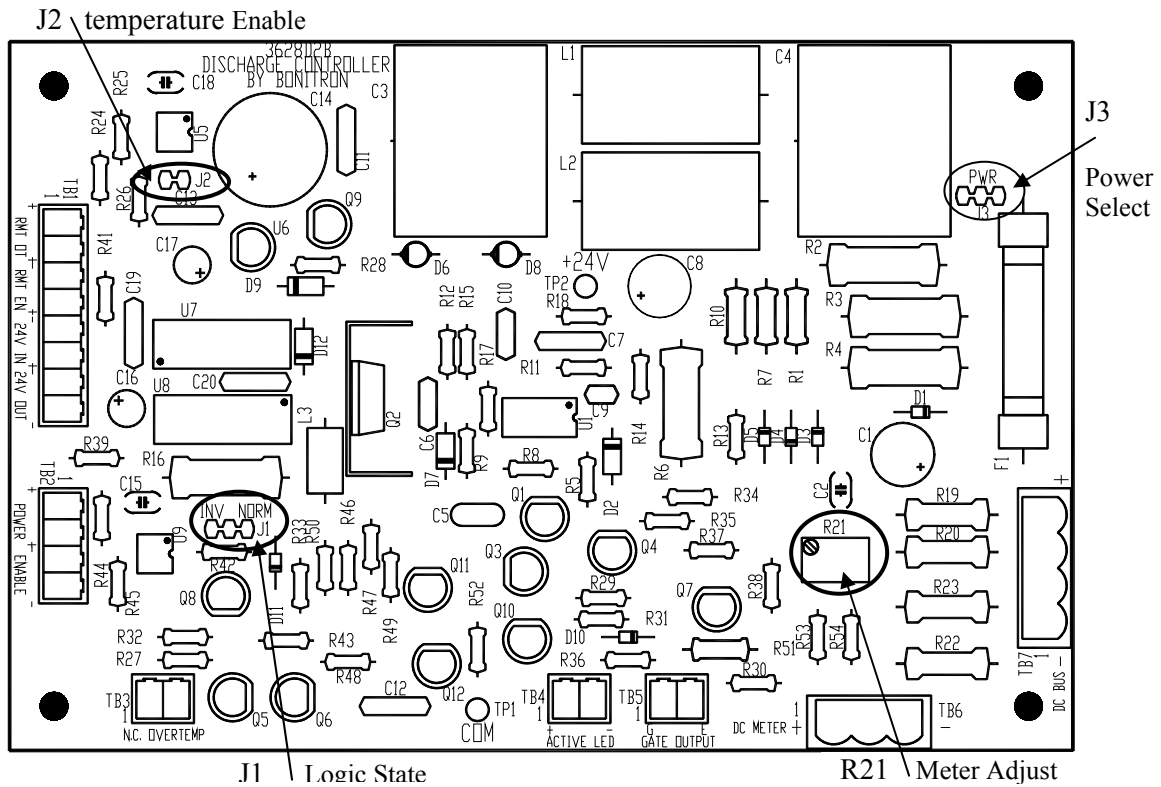
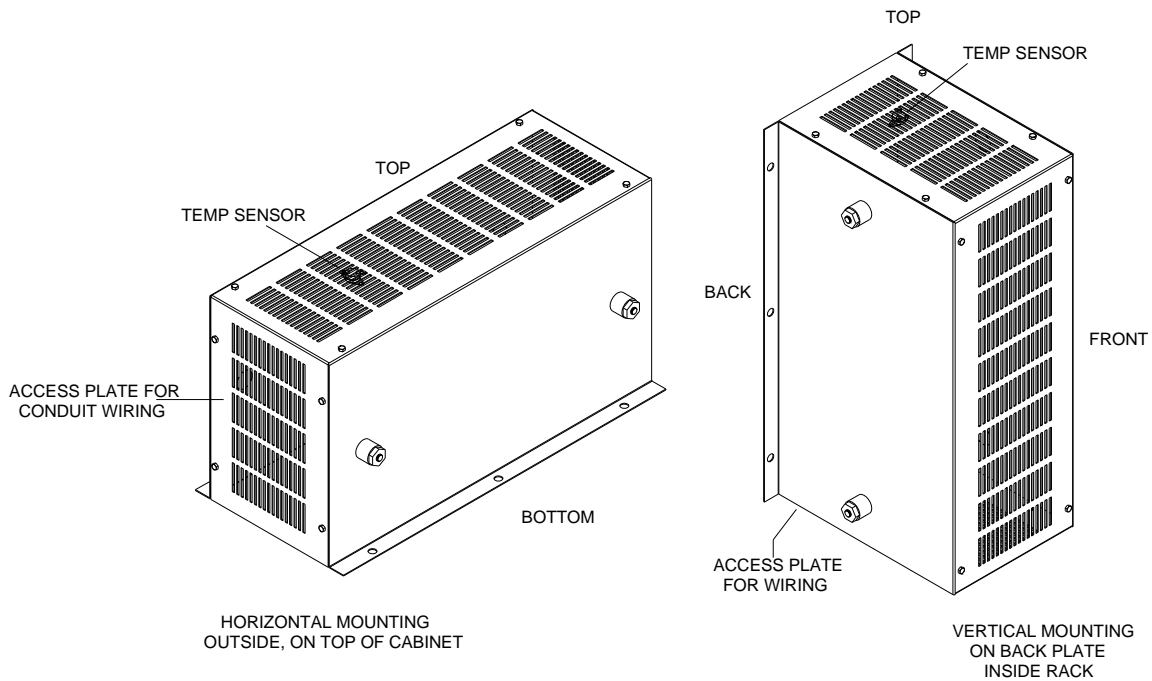
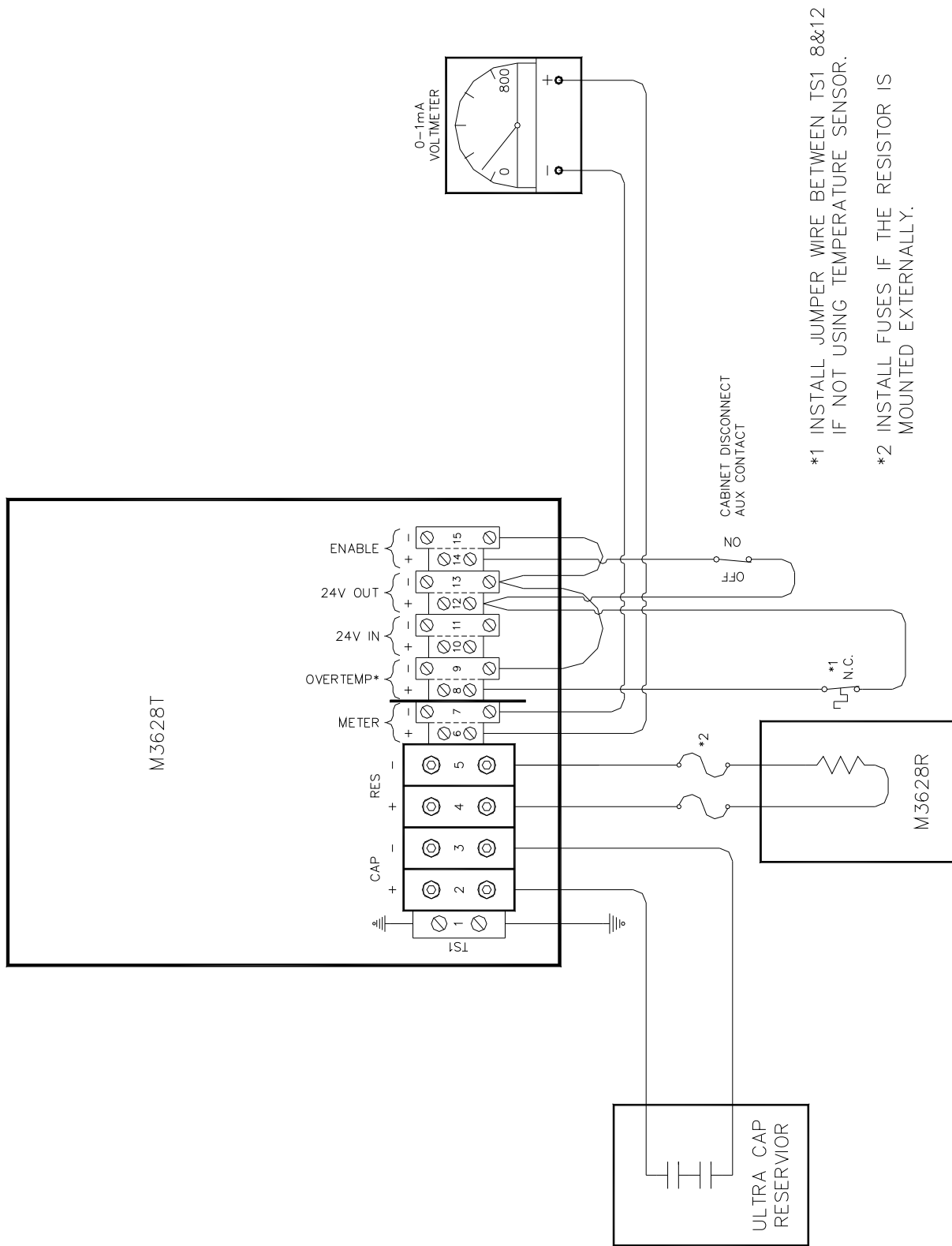

Figure 3-4: Temperature Sensor Placement



1. USE TEFLON HIGH TEMP WIRE
2. SECURE WIRES TO EXTERNAL MOUNT, PULLING THEM AWAY FROM CHASSIS
DO NOT SECURE WIRE TO CHASSIS

Figure 3-5: M3628 System Control Interface Wiring



3.5. TYPICAL CONFIGURATION

Figure 3-6: Ride-Thru System Configuration 18

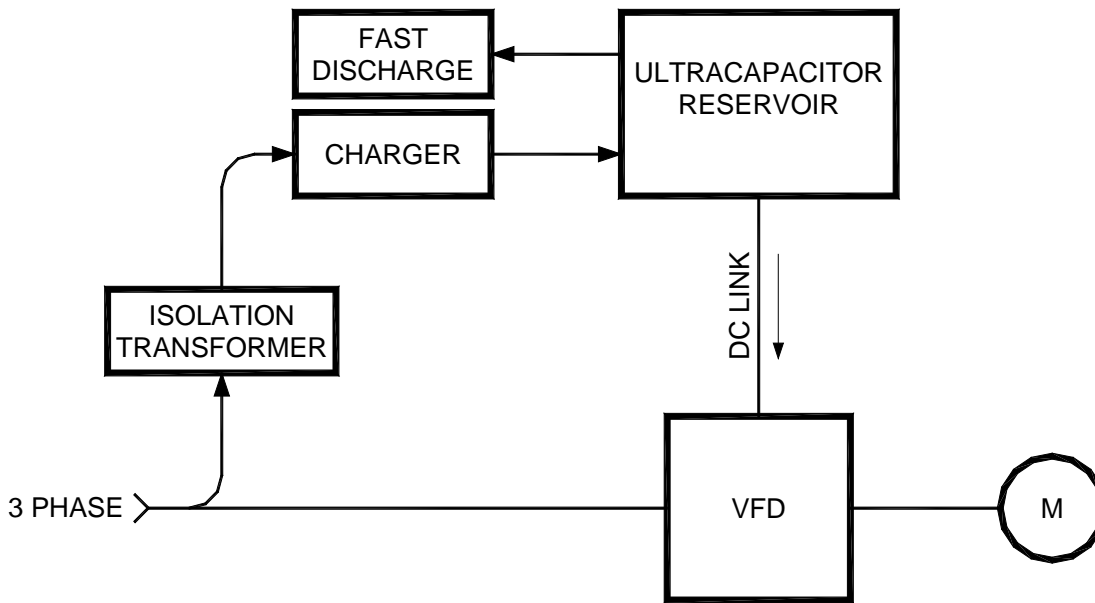

ABOVE 50KW, 0.1 - 0.5 SECOND, 100% OUTAGE PROTECTION
 USING ULTRACAPACITOR RESERVOIR
 SINGLE CABINET POWERED FROM AC LINE

Figure 3-7: Ride-Thru System Configuration 2

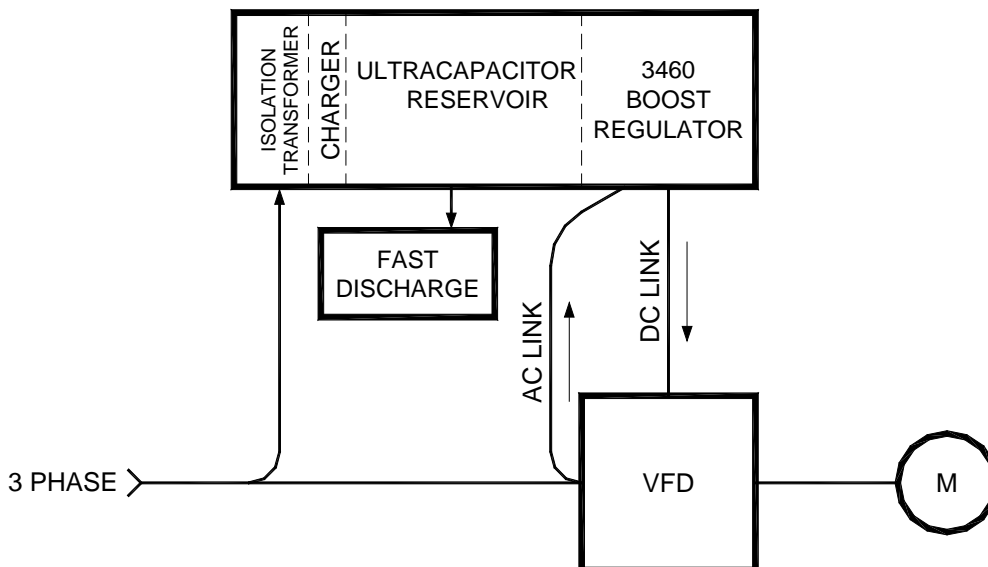

ABOVE 50KW, 0.5 - 2 SECOND, 100% OUTAGE PROTECTION
 USING DC BOOSTER WITH ULTRA CAP RESERVOIR
 SINGLE CABINET POWERED FROM AC LINE

Figure 3-8: 100% Outage Ride-Thru System Without Booster

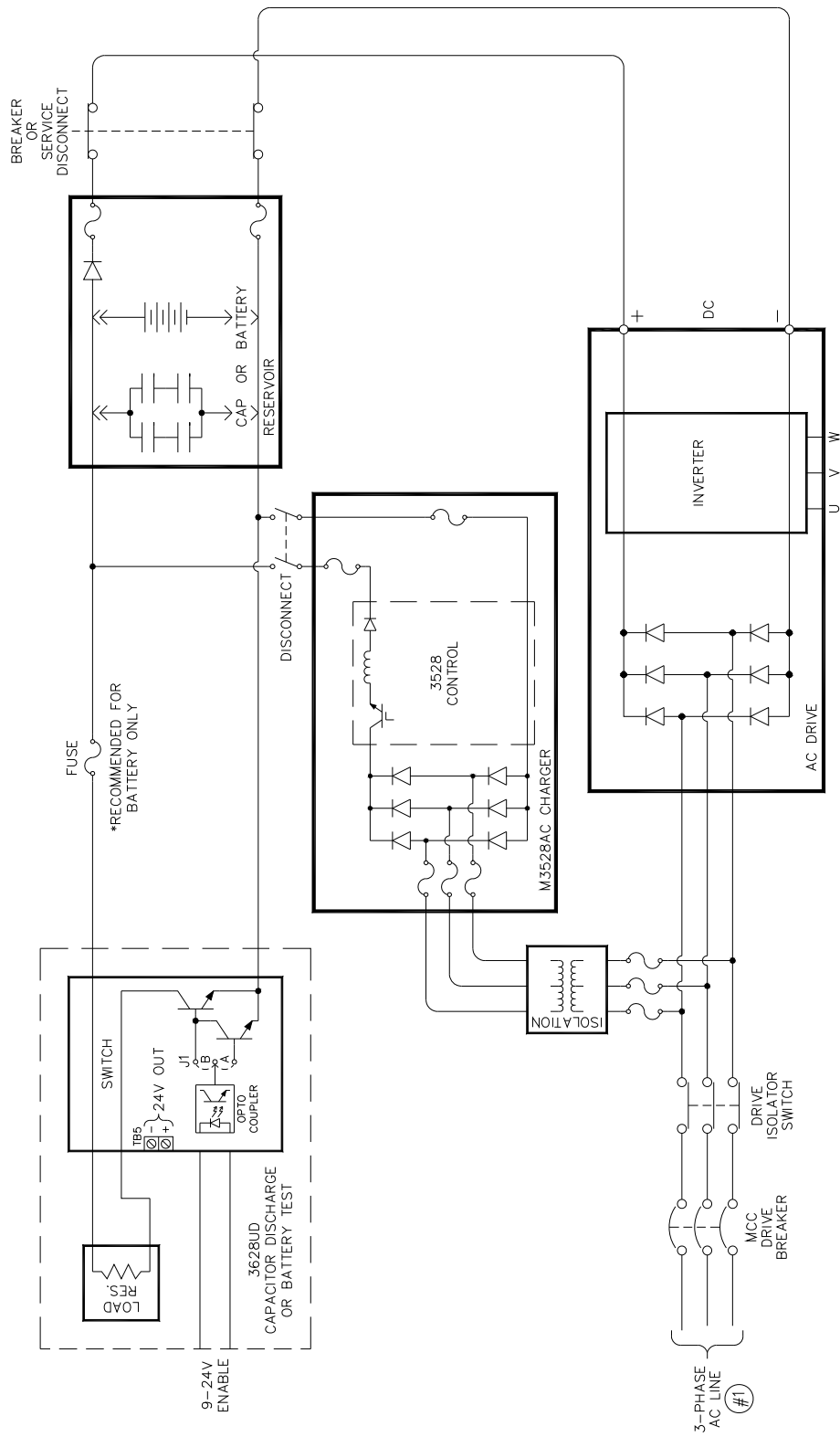

4. OPERATION

4.1. FUNCTIONAL DESCRIPTION

The M3628T IGBT switch can be self powered from the capacitor bank, or from an external 24V 50mA source.

Under normal conditions the discharger is connected to an ultracapacitor bank held at zero volts. When charging begins and the capacitor bank voltage increases to about 150VDC, the internal power supply will begin switching (DC power LED turns ON) and 24VDC is created for logic control. At this point if the IGBT is already enabled, it will turn ON, and if not it should remain OFF. The discharger will remain in this state while charging continues, and until the enable command is changed.

The discharger can be set up for normal or inverted operation. In normal mode a 24V enable signal to the discharger will cause the IGBT switch to turn ON. In invert mode a 24V enable signal to the discharger will hold the IGBT switch OFF.

The discharge cycle can be started or stopped at any time via the optically coupled 24VDC enable input. A typical discharge cycle would see the enable given and the capacitor bank voltage begin to decrease. When the capacitor bank voltage gets down to about 15VDC the discharger will turn itself OFF. When the discharger turns itself OFF the capacitor bank will begin to reform a little and as the voltage creeps back up to 18V the IGBT again turns on discharging the capacitor more. This cycling may continue for several minutes depending on the capacitor cell design. Once the capacitor voltage drops to about 8V the discharger controller will shut down and the IGBT will not be turned on again until the capacitor voltage again gets above 150VDC.

Temperature feedback from internal IGBT heatsink is used to shut down the discharge automatically in case of extreme cycling or misuse. External temperature feedback can be connected to protect cabinet components and is isolated from capacitor bank potential.

An external 0-1mA meter with a 800V scale can be connected to display the storage bank voltage to confirm discharge or loading has occurred.

4.2. FEATURES

4.2.1. INDICATORS

- DC Power – means 24V Control power is present. Search for intensity and charge accordingly.
- Enable means 24V is present at the ENABLE input.
- Active – means IGBT switch is on.

4.2.2. BUS VOLTAGE

- Connection for 0-1mA 800V meter available. This output is not electrically isolated from capacitor input.

4.2.3. 24V SUPPLY

- An **ISOLATED** 24V output is available for use with the Enable and RMT OT inputs.
- A 24VDC input is available for portable discharge models and for applications where caps must be drained below 15V.

4.2.4. DISCHARGE SWITCH PCB JUMPERS

J1 = Selects Enable Logic state

- NORM = High in turns Switch ON
- INV = High in turns Switch OFF
- Shipped in INV position so that when 24V enable input is removed, the switch turns ON

J2 = Enables external temperature sensor input

- ON = Disabled
- OFF = Enabled
- Shipped in OFF position so that external temperature input to module is enabled

J3 = Chooses IGBT switch's control power source

- ON = Connects Capacitor bank DC input to internally generated 24V logic supply
 - a. Used for typical Ride-Thru applications with no external DC supply
- OFF = For use with external 24VDC input. No connection to internally generated supply
 - a. Used when discharging to zero volts is needed
- Used if discharging must occur at low voltages before internal supply can start up
- Shipped in ON position so that control power is derived from capacitor DC input.

Refer to Table 3-2.

4.3. STARTUP

4.3.1. PRE-POWER CHECKS

- Ensure ENABLE logic is correct. See Table 3-2.
- Ensure DC bus polarity is correct.
- Ohm resistor bank at switch module output for proper value.

4.3.2. STARTUP PROCEDURE

1. Apply power to Drive system and allow time for precharge of VSD.
 - a. Ultracap bank voltage should not increase if properly diode isolated
2. Apply AC power to charger and watch Ultracapacitor voltage increase from charge current.
 - Rise time is dependent on capacitor bank value and charge current level.
 - M3628T switch module DC power LED should begin to illuminate as DC bus increases past 150VDC.
 - 0-1mA= 800VDC meter should show capacitor bank voltage as it increases.

4.3.3. DISCHARGE PROCEDURE



Applying ENABLE with system power on can cause excessive heating in the electronic switch and resistor bank depending on the power capability of the charging device. The unit is designed for 1 minute drain to 50VDC of a properly matched storage bank.

3. Remove AC power from system.
 - VFD bus will drop to storage bank value. With no load the VFD should remain powered from storage reservoir, and not fault.
4. Turn on the M3628T discharge switch.
 - Active LED should illuminate.
 - Storage bus should begin to decrease in voltage.
 - Load resistor will begin to heat up.
 - Systems are typically designed so that in less than 1 minute the storage bank voltage should be less than 50V.
 - IGBT switch will continue to drain capacitor bank until its voltage drops below 12VDC.
5. If excessive heat is noticed, the discharge cycle can be aborted by removing the enable signal at any time during the discharge cycle, but power to continue the discharge cycle will be lost once the capacitor voltage drops below 8VDC. After that, an external 18-28VDC will be required to finish discharge to zero volts.
 - Internal temperature sensor will automatically shut down IGBT switch in case of over temperature.
 - External temperature sensor can be used to shutdown IGBT switch in order to protect resistor or other components in enclosure.
6. When the gate drive has dropped too low the capacitor bank voltage will begin to increase. As it increases back toward 15V the IGBT gate will again enable and the capacitor bank will again discharge. This cycle will continue until the capacitor bank no longer rebounds enough to reach the turn on threshold. At this point a shorting bar or low ohm resistor can be placed across capacitor terminals to keep residual charge from building.
 - If the resistor and IGBT switch have been designed so that the capacitor voltage has dropped to 50VDC in 1 minute, the IGBT switch will have enough storage to drain the capacitor below 10VDC.



A spark may be produced when connecting shorting jumper even with as little as 10V across cap. Use resistive jumper or large enough wire to handle peak current. Do not short if explosive gasses are present.



If IGBT switch is connected to external isolated 24V supply, switch will keep load connected as long as Enable is active and the capacitor bank can be held below 2V.

4.4. NO OPERATIONAL ADJUSTMENTS

4.5. CALIBRATION

If calibration of the voltage meter output is needed:

1. Remove cover to access the control PCB 3628D2.
2. Adjust R21 until meter reads accurately.
 - CW increases deflection.
 - CCW decreases deflection.

NOTE: Circuit is designed for 0 – 800V meter scale.

This page intentionally left blank

5. MAINTENANCE AND TROUBLESHOOTING

Repairs or modifications to this equipment are to be performed by Bonitron approved personnel only. Any repair or modification to this equipment by personnel not approved by Bonitron will void any warranty remaining on this unit.

5.1. PERIODIC TESTING

No periodic testing is required, although the M3628 units may be used to periodically test capacitor bank for storage capacity.

5.2. MAINTENANCE ITEMS

None.

5.3. TROUBLESHOOTING

5.3.1. UNIT WILL NOT DISCHARGE STORAGE RESERVOIR

- Ensure storage bank is properly connected and fuses (if fused) are intact
- Ensure load resistor is properly connected and fuses (if fused) are intact
- Ensure DC POWER LED is on
 - See "No DC POWER LED" 5.3.3
- Check enable input voltage and logic state
 - See "No ENABLE LED" 5.3.4
- Check temperature sensors for proper operation
 - See "OVER-TEMP" 5.3.6

5.3.2. UNIT WILL NOT ALLOW STORAGE RESERVOIR TO CHARGE

- Ensure storage bank is properly connected
- Ensure load resistor is properly connected
- Ensure ENABLE is correct logic state (Active LED off)
- Ensure gate lead connector is in place at TB5 on 3628D2 control pcb
- Replace M3628T

5.3.3. No DC POWER LED

- Check for proper position of J3
- Check incoming DC POWER to be 20VDC and 26VDC
- Ensure DC POWER LED wires are properly terminated
- Ensure all connectors are in place on 3628D2 control pcb
- Check LED for proper operation
- Replace M3628T

5.3.4. No ENABLE LED

- Check enable input voltage to be above 20VDC in NORMAL mode
- Ensure Enable LED wires are properly terminated
- Ensure all connectors are in place on 3628D2 control pcb
- Ensure J1 is in proper position
- Check LED for proper operation
- Replace M3628T

5.3.5. **No ACTIVE LED**

- Ensure J1 is in proper position for ENABLE logic
- Ensure switch is not overheated
- Ensure DC input is above 150VDC
- Replace M3628T

5.3.6. **OVER-TEMPERATURE**

- Measure internal temperature sensor
 - Should be shorted under normal conditions
 - Will be open under high temperature condition
 - Replace sensor if not correct
- Measure external temperature sensor
 - Should be shorted under normal conditions
 - Will be open under high temperature condition
 - Replace sensor if not correct
 - Ensure external sensor wire run is short and does not come in proximity to “noisy” power wiring

6. ENGINEERING DATA

6.1. RATINGS CHARTS

Table 6-1: Typical Discharge Packages for 230VAC Systems

| POWER ACCEPTANCE (KJOULES) | CAP BANK VOLTAGE @ IGBT AMP RATING (DC VOLTS) | OHMS | BONITRON M3628R RESISTOR PART # | IGBT SWITCH RATING (PEAK AMPS) | RMS AMPS FOR SINGLE DISCHARGE | BONITRON M3628T IGBT SWITCH PART # |
|----------------------------|---|------|---------------------------------|--------------------------------|-------------------------------|------------------------------------|
| 350 | 150 | 2 | M3628R-02.0-0350-6T | 75 | 22 | M3628T-L075-M4 |
| 350 | 225 | 3 | M3628R-03.0-0350-6T | 75 | 22 | M3628T-L075-M4 |
| 350 | 300 | 4 | M3628R-04.0-0350-6T | 75 | 22 | M3628T-L075-M4 |
| 750 | 150 | 2 | M3628R-02.0-0750-6H | 75 | 22 | M3628T-L075-M4 |
| 750 | 225 | 3 | M3628R-03.0-0750-6H | 75 | 22 | M3628T-L075-M4 |
| 750 | 300 | 4 | M3628R-04.0-0750-6H | 75 | 22 | M3628T-L075-M4 |
| 1500 | 150 | 1 | M3628R-01.0-1500-6H | 150 | 44 | M3628T-L150-B5 |
| 1500 | 225 | 1.5 | M3628R-01.5-1500-6H | 150 | 44 | M3628T-L150-B5 |
| 1500 | 300 | 2 | M3628R-02.0-1500-6H | 150 | 44 | M3628T-L150-B5 |
| 2000 | 180 | 0.6 | M3628R-00.6-2000-6H | 300 | 87 | M3628T-L300-B7 |
| 2000 | 240 | 0.8 | M3628R-00.8-2000-6H | 300 | 87 | M3628T-L300-B7 |
| 2000 | 300 | 1 | M3628R-01.0-2000-6H | 300 | 87 | M3628T-L300-B7 |
| 3000 | 180 | 0.3 | M3628R-00.3-3000-10H | 600 | 174 | M3628T-L600-B7 |
| 3000 | 240 | 0.4 | M3628R-00.4-3000-10H | 600 | 174 | M3628T-L600-B7 |
| 3000 | 300 | 0.5 | M3628R-00.5-3000-10H | 600 | 174 | M3628T-L600-B7 |
| 4000 | 180 | 0.3 | M3628R-00.3-4000-14H | 600 | 174 | M3628T-L600-B7 |
| 4000 | 240 | 0.4 | M3628R-00.4-4000-14H | 600 | 174 | M3628T-L600-B7 |
| 4000 | 300 | 0.5 | M3628R-00.5-4000-14H | 600 | 174 | M3628T-L600-B7 |

M3628 R&T

Table 6-2: Typical Discharge Packages for 400VAC Systems

| POWER ACCEPTANCE (KJOULES) | CAP BANK VOLTAGE @ IGBT AMP RATING (DC VOLTS) | OHMS | BONITRON M3628R RESISTOR PART # | IGBT SWITCH RATING (PEAK AMPS) | RMS AMPS FOR SINGLE DISCHARGE | BONITRON M3628T IGBT SWITCH PART # |
|----------------------------|---|------|---------------------------------|--------------------------------|-------------------------------|------------------------------------|
| 350 | 300 | 4 | M3628R-04.0-0350-6T | 75 | 22 | M3628T-H075-M4 |
| 350 | 375 | 5 | M3628R-05.0-0350-6T | 75 | 22 | M3628T-H075-M4 |
| 350 | 450 | 6 | M3628R-06.0-0350-6T | 75 | 22 | M3628T-H075-M4 |
| 350 | 525 | 7 | M3628R-07.0-0350-6T | 75 | 22 | M3628T-H075-M4 |
| 750 | 300 | 4 | M3628R-04.0-0750-6H | 75 | 22 | M3628T-L075-M4 |
| 750 | 375 | 5 | M3628R-05.0-0750-6H | 75 | 22 | M3628T-H075-M4 |
| 750 | 450 | 6 | M3628R-06.0-0750-6H | 75 | 22 | M3628T-H075-M4 |
| 750 | 525 | 7 | M3628R-07.0-0750-6H | 75 | 22 | M3628T-H075-M4 |
| 1500 | 300 | 2 | M3628R-02.0-1500-6H | 150 | 44 | M3628T-L150-B5 |
| 1500 | 375 | 2.5 | M3628R-02.5-1500-6H | 150 | 44 | M3628T-H150-B5 |
| 1500 | 450 | 3 | M3628R-03.0-1500-6H | 150 | 44 | M3628T-H150-B5 |
| 1500 | 525 | 3.5 | M3628R-03.5-1500-6H | 150 | 44 | M3628T-H150-B5 |
| 2000 | 300 | 1 | M3628R-01.0-2000-6H | 300 | 87 | M3628T-L300-B7 |
| 2000 | 360 | 1.2 | M3628R-01.2-2000-6H | 300 | 87 | M3628T-H300-B7 |
| 2000 | 420 | 1.4 | M3628R-01.4-2000-6H | 300 | 87 | M3628T-H300-B7 |
| 2000 | 480 | 1.6 | M3628R-01.6-2000-6H | 300 | 87 | M3628T-H300-B7 |
| 2000 | 540 | 1.8 | M3628R-01.8-2000-6H | 300 | 87 | M3628T-H300-B7 |
| 3000 | 300 | 0.5 | M3628R-00.5-3000-10H | 600 | 174 | M3628T-L600-B7 |
| 3000 | 360 | 0.6 | M3628R-00.6-3000-10H | 600 | 174 | M3628T-H600-B7 |
| 3000 | 420 | 0.7 | M3628R-00.7-3000-10H | 600 | 174 | M3628T-H600-B7 |
| 3000 | 480 | 0.8 | M3628R-00.8-3000-10H | 600 | 174 | M3628T-H600-B7 |
| 3000 | 540 | 0.9 | M3628R-00.9-3000-10H | 600 | 174 | M3628T-H600-B7 |
| 4000 | 300 | 0.5 | M3628R-00.5-4000-14H | 600 | 174 | M3628T-L600-B7 |
| 4000 | 360 | 0.6 | M3628R-00.6-4000-14H | 600 | 174 | M3628T-H600-B7 |
| 4000 | 420 | 0.7 | M3628R-00.7-4000-14H | 600 | 174 | M3628T-H600-B7 |
| 4000 | 480 | 0.8 | M3628R-00.8-4000-14H | 600 | 174 | M3628T-H600-B7 |
| 4000 | 540 | 0.9 | M3628R-00.9-4000-14H | 600 | 174 | M3628T-H600-B7 |

Table 6-3: Typical Discharge Packages for 460VAC Systems

| POWER ACCEPTANCE (KJOULES) | CAP BANK VOLTAGE @ IGBT AMP RATING (DC VOLTS) | OHMS | BONITRON M3628R RESISTOR PART # | IGBT SWITCH RATING (PEAK AMPS) | RMS AMPS FOR SINGLE DISCHARGE | BONITRON M3628T IGBT SWITCH PART # |
|----------------------------|---|------|---------------------------------|--------------------------------|-------------------------------|------------------------------------|
| 350 | 375 | 5 | M3628R-05.0-0350-6T | 75 | 22 | M3628T-H075-M4 |
| 350 | 450 | 6 | M3628R-06.0-0350-6T | 75 | 22 | M3628T-H075-M4 |
| 350 | 525 | 7 | M3628R-07.0-0350-6T | 75 | 22 | M3628T-H075-M4 |
| 350 | 600 | 8 | M3628R-08.0-0350-6T | 75 | 22 | M3628T-H075-M4 |
| 750 | 375 | 5 | M3628R-05.0-0750-6H | 75 | 22 | M3628T-H075-M4 |
| 750 | 450 | 6 | M3628R-06.0-0750-6H | 75 | 22 | M3628T-H075-M4 |
| 750 | 525 | 7 | M3628R-07.0-0750-6H | 75 | 22 | M3628T-H075-M4 |
| 750 | 600 | 8 | M3628R-08.0-0750-6H | 75 | 22 | M3628T-H075-M4 |
| 1500 | 375 | 2.5 | M3628R-02.5-1500-6H | 150 | 44 | M3628T-H150-B5 |
| 1500 | 450 | 3 | M3628R-03.0-1500-6H | 150 | 44 | M3628T-H150-B5 |
| 1500 | 525 | 3.5 | M3628R-03.5-1500-6H | 150 | 44 | M3628T-H150-B5 |
| 1500 | 600 | 4 | M3628R-04.0-1500-6H | 150 | 44 | M3628T-H150-B5 |
| 2000 | 360 | 1.2 | M3628R-01.2-2000-6H | 300 | 87 | M3628T-H300-B7 |
| 2000 | 420 | 1.4 | M3628R-01.4-2000-6H | 300 | 87 | M3628T-H300-B7 |
| 2000 | 480 | 1.6 | M3628R-01.6-2000-6H | 300 | 87 | M3628T-H300-B7 |
| 2000 | 540 | 1.8 | M3628R-01.8-2000-6H | 300 | 87 | M3628T-H300-B7 |
| 2000 | 600 | 2 | M3628R-02.0-2000-6H | 300 | 87 | M3628T-H300-B7 |
| 3000 | 360 | 0.6 | M3628R-00.6-3000-10H | 600 | 174 | M3628T-H600-B7 |
| 3000 | 420 | 0.7 | M3628R-00.7-3000-10H | 600 | 174 | M3628T-H600-B7 |
| 3000 | 480 | 0.8 | M3628R-00.8-3000-10H | 600 | 174 | M3628T-H600-B7 |
| 3000 | 540 | 0.9 | M3628R-00.9-3000-10H | 600 | 174 | M3628T-H600-B7 |
| 3000 | 600 | 1 | M3628R-01.0-3000-10H | 600 | 174 | M3628T-H600-B7 |
| 4000 | 360 | 0.6 | M3628R-00.6-4000-14H | 600 | 174 | M3628T-H600-B7 |
| 4000 | 420 | 0.7 | M3628R-00.7-4000-14H | 600 | 174 | M3628T-H600-B7 |
| 4000 | 480 | 0.8 | M3628R-00.8-4000-14H | 600 | 174 | M3628T-H600-B7 |
| 4000 | 540 | 0.9 | M3628R-00.9-4000-14H | 600 | 174 | M3628T-H600-B7 |
| 4000 | 600 | 1 | M3628R-01.0-4000-14H | 600 | 174 | M3628T-H600-B7 |

M3628 R&T

Table 6-4: Typical Discharge Packages for 600VAC Systems

| POWER ACCEPTANCE (KJOULES) | CAP BANK VOLTAGE @ IGBT AMP RATING (DC VOLTS) | OHMS | BONITRON M3628R RESISTOR PART # | IGBT SWITCH RATING (PEAK AMPS) | RMS AMPS FOR SINGLE DISCHARGE | BONITRON M3628T IGBT SWITCH PART # |
|----------------------------|---|------|---------------------------------|--------------------------------|-------------------------------|------------------------------------|
| 350 | 525 | 7 | M3628R-07.0-0350-6T | 75 | 22 | M3628T-H075-M4 |
| 350 | 600 | 8 | M3628R-08.0-0350-6T | 75 | 22 | M3628T-H075-M4 |
| 350 | 675 | 9 | M3628R-09.0-0350-6T | 75 | 22 | M3628T-H075-M4 |
| 350 | 750 | 10 | M3628R-10.0-0350-6T | 75 | 22 | M3628T-H075-M4 |
| 750 | 525 | 7 | M3628R-07.0-0750-6H | 75 | 22 | M3628T-H075-M4 |
| 750 | 600 | 8 | M3628R-08.0-0750-6H | 75 | 22 | M3628T-H075-M4 |
| 750 | 675 | 9 | M3628R-09.0-0750-6H | 75 | 22 | M3628T-H075-M4 |
| 750 | 750 | 10 | M3628R-10.0-0750-6H | 75 | 22 | M3628T-H075-M4 |
| 1500 | 525 | 3.5 | M3628R-03.5-1500-6H | 150 | 44 | M3628T-H150-B5 |
| 1500 | 600 | 4 | M3628R-04.0-1500-6H | 150 | 44 | M3628T-H150-B5 |
| 1500 | 675 | 4.5 | M3628R-04.5-1500-6H | 150 | 44 | M3628T-H150-B5 |
| 1500 | 750 | 5 | M3628R-05.0-1500-6H | 150 | 44 | M3628T-H150-B5 |
| 2000 | 540 | 1.8 | M3628R-01.8-2000-6H | 300 | 87 | M3628T-H300-B7 |
| 2000 | 600 | 2 | M3628R-02.0-2000-6H | 300 | 87 | M3628T-H300-B7 |
| 2000 | 660 | 2.2 | M3628R-02.2-2000-6H | 300 | 87 | M3628T-H300-B7 |
| 2000 | 720 | 2.4 | M3628R-02.4-2000-6H | 300 | 87 | M3628T-H300-B7 |
| 2000 | 780 | 2.6 | M3628R-02.6-2000-6H | 300 | 87 | M3628T-H300-B7 |
| 3000 | 540 | 0.9 | M3628R-00.9-3000-10H | 600 | 174 | M3628T-H600-B7 |
| 3000 | 600 | 1 | M3628R-01.0-3000-10H | 600 | 174 | M3628T-H600-B7 |
| 3000 | 660 | 1.1 | M3628R-01.1-3000-10H | 600 | 174 | M3628T-H600-B7 |
| 3000 | 720 | 1.2 | M3628R-01.2-3000-10H | 600 | 174 | M3628T-H600-B7 |
| 3000 | 780 | 1.3 | M3628R-01.3-3000-10H | 600 | 174 | M3628T-H600-B7 |
| 4000 | 540 | 0.9 | M3628R-00.9-4000-14H | 600 | 174 | M3628T-H600-B7 |
| 4000 | 600 | 1 | M3628R-01.0-4000-14H | 600 | 174 | M3628T-H600-B7 |
| 4000 | 660 | 1.1 | M3628R-01.1-4000-14H | 600 | 174 | M3628T-H600-B7 |
| 4000 | 720 | 1.2 | M3628R-01.2-4000-14H | 600 | 174 | M3628T-H600-B7 |
| 4000 | 780 | 1.3 | M3628R-01.3-4000-14H | 600 | 174 | M3628T-H600-B7 |

6.2. WATT LOSS

Table 6-5: Watt Loss During a Single Discharge Cycle

| 460V SWITCH MODELS | 3628T IGBT MODULES | | |
|--------------------|--------------------|---------------|----------------------|
| | PEAK WATT LOSS | RMS WATT LOSS | CONTINUOUS WATT LOSS |
| 3628T-EH075 | 187 | 55 | 19 |
| 3628T-EH150 | 315 | 92 | 32 |
| 3628T-EH300 | 510 | 148 | 51 |
| 3628T-EH600 | 1260 | 365 | 126 |

M3628R Resistor modules are designed to dissipate power. The actual watts dissipated must be calculated using the actual capacitor bank energy being discharged.

6.3. CERTIFICATIONS

M3628T is Listed and M3628R is Recognized under UL508C standards for use with ultracapacitors.

6.4. FUSE/CIRCUIT BREAKER SIZING AND RATING

DISCHARGER - CAPACITIVE STORAGE BANK DC LINK:

For capacitive energy discharge systems, fusing between capacitor reservoir and M3628T switch is not recommended unless local safety codes require it due to location of units and wiring protection. If the fuse ever blows, there will no longer be discharge capability. If fusing in this link is required or desired, see Table 6-6 for fuse sizes.

RESISTOR - CAPACITIVE STORAGE BANK LOAD:

If resistor is externally mounted, a semiconductor fuse should be used in both legs. Fuse rating should match peak current seen by actual application.

DISCHARGER - BATTERY STORAGE BANK DC LINK:

For battery energy load testing systems, fusing between battery bank and switch is recommended due to large amounts of stored energy in battery bank. Fuse should be sized by system designer according to actual load and duration of battery testing.

STORAGE BANK - INVERTER DC LINK:

Fusing between capacitor bank and inverter is recommended for capacitive storage systems to protect the drive system and the storage bank. Fusing must be able to allow the maximum current at the minimum usable capacitor bank voltage without fatigue, and should be able to protect the blocking diode. Blocking diode and fuse ratings can be down sized considering the short time current is flowing. Fuse values for this are very application dependent and should be chosen by the system designer. The following fuse ratings are guidelines for Discharger – Capacitor DC links:

Table 6-6: Recommended Fuse Range

| MODEL | RECOMMENDED FUSE RANGE |
|-------------|-----------------------------|
| M3628T-H075 | 35-40 Amp time delay type |
| M3628T-H150 | 75-80 Amp time delay type |
| M3628T-H300 | 150-175 Amp time delay type |
| M3628T-H600 | 300-350 Amp time delay type |

6.5. DIMENSIONS AND MECHANICAL DRAWINGS

Figure 6-1: M3628T Chassis Dimensional Outline Drawing

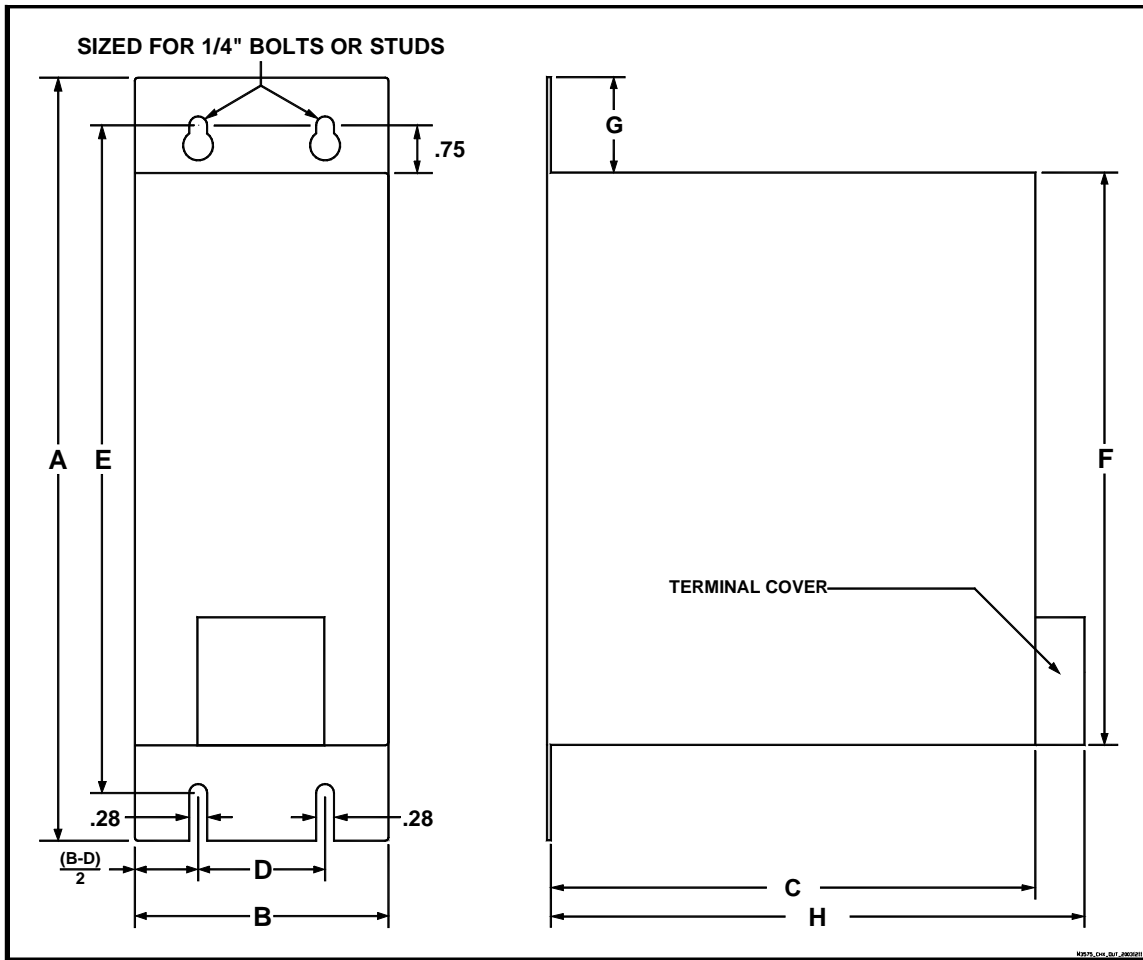

Table 6-7: M3628T Chassis Dimensions

| CHASSIS | DIM. A | DIM. B | DIM. C | DIM. D | DIM. E | DIM. F | DIM. G | DIM. H | |
|---------|--------|--------|--------|--------|--------|--------|--------|-----------|---------|
| | | | | | | | | w/o cover | w/cover |
| M4 | 12.75 | 4.00 | 7.70 | 1.75 | 12.00 | 10.50 | 1.13 | 8.30 | 9.50 |
| B5 | 17.75 | 5.50 | 7.80 | 3.00 | 16.75 | 14.50 | 1.36 | 8.40 | 9.60 |
| B7 | 17.75 | 7.00 | 7.70 | 5.00 | 16.75 | 15.00 | 1.38 | 8.30 | 9.50 |

| MODEL | CHASSIS |
|-------------|---------|
| M3628T-H075 | M4 |
| M3628T-H150 | B5 |

| MODEL | CHASSIS |
|-------------|---------|
| M3628T-H300 | B7 |
| M3628T-H600 | B7 |

Figure 6-2: M3628R Dimensional Outline

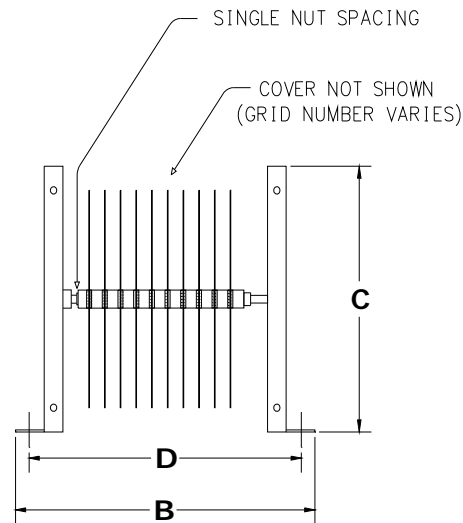
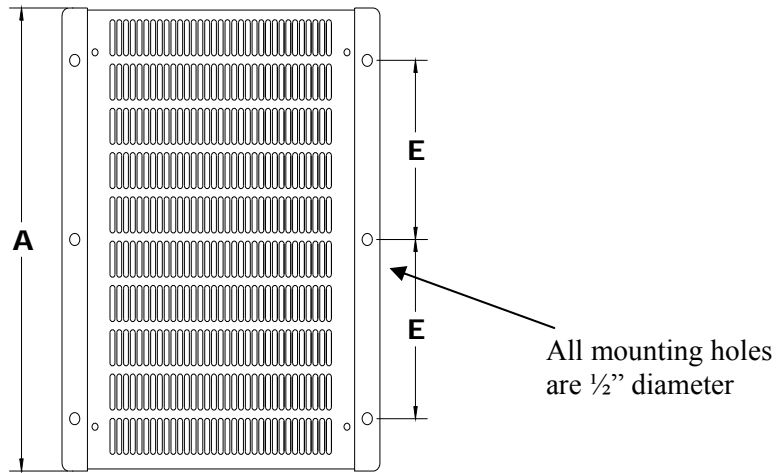

Table 6-8: M3628R Chassis Dimensions

| CHASSIS CODE | DIM. A | DIM. B | DIM. C | DIM. D | DIM. E |
|--------------|--------|--------|--------|--------|--------|
| 6T | 10 | 13 | 7.5 | 11.5 | N/A |
| 6H | 25.6 | 12.25 | 14.0 | 10.75 | 10.00 |
| 10H | 25.6 | 16.00 | 14.0 | 14.50 | 10.00 |
| 14H | 25.6 | 20.00 | 14.0 | 18.50 | 10.00 |

| MODEL | CHASSIS |
|------------------|---------|
| M3628R-xx.x-0350 | 6T |
| M3628R-xx.x-0750 | 6H |
| M3628R-xx.x-1500 | 6H |

| MODEL | CHASSIS |
|------------------|---------|
| M3628R-xx.x-2000 | 6H |
| M3628R-xx.x-3000 | 10H |
| M3628R-xx.x-4000 | 14H |

6.6. BLOCK DIAGRAMS

Figure 6-3: 75-600A Fast Discharge Basic Schematic

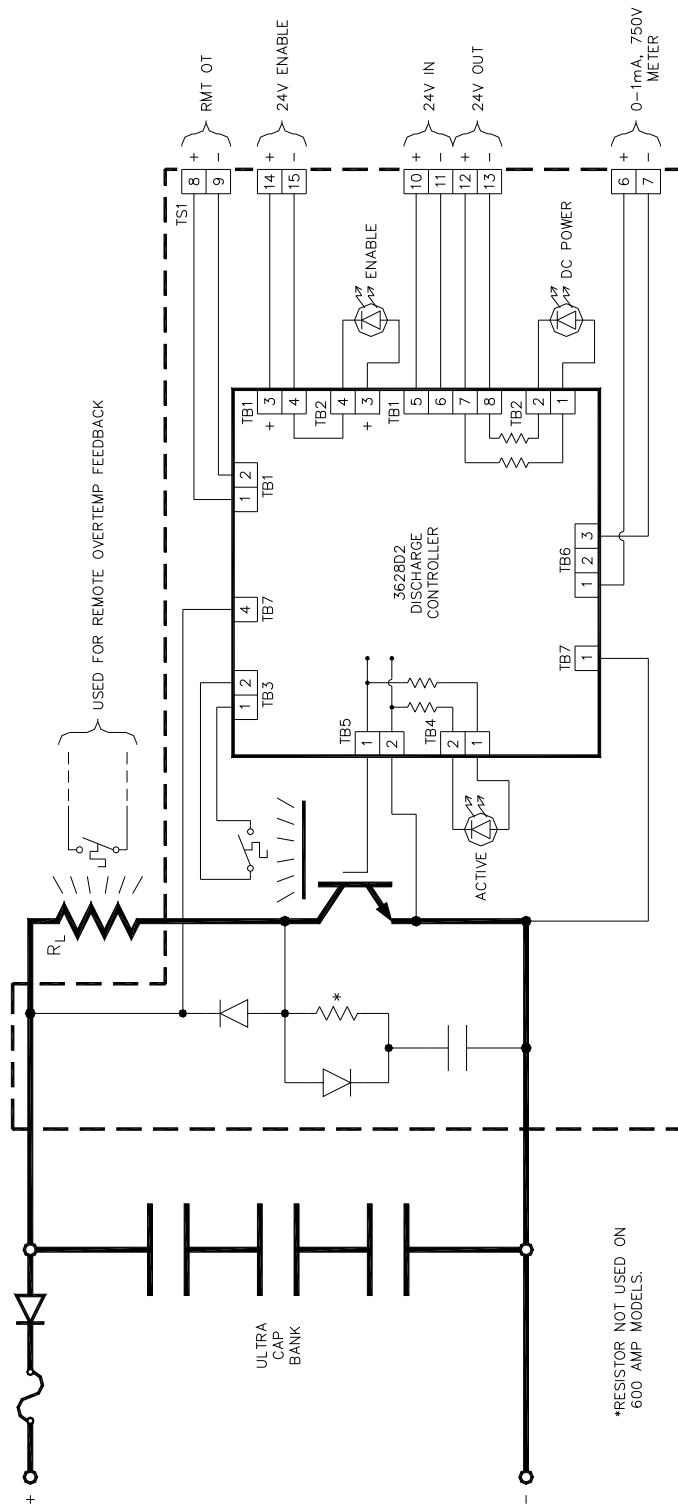

7. APPENDIX

7.1. APPLICATION NOTES

7.1.1. CONTROL SCHEMES

There are three basic scenarios for control logic. All Standard Bonitron Ultracapacitor cabinets will be shipped with the Automatic Discharge Control scheme.

1. Automatic discharge when cabinet door disconnect is turned off. This method is best for personnel safety as it ensures capacitor bank is discharged and safe within 1 minute after the door disconnect is opened.
 - a. Internal 24V is fed to Enable input via door disconnect aux contact.
 - i. Set up IGBT switch for inverted operation (J1 in INV position) so that with 24V connected to Enable the IGBT is off, and discharge does not occur.
 - a. When the door disconnect is opened, the enable is removed, and the discharge cycle begins.
 - ii. The internal 24V supply does not have enough energy storage to run both the IGBT gate and the enable opto coupler so operation in normal mode may not fully discharge the capacitor bank.
2. Manual discharge from local source when desired. This method is best if process is paramount concern as it has least chance of false discharge cycle which ensures caps are fully charged.
 - a. 9V battery or 24V source capable of 20mA is temporarily connected to enable input via connector on door or connector inside cabinet.
 - i. Set up IGBT switch for normal operation (J1 in NORM position)
 - a. When 24V is applied the enable is given and the discharge cycle begins
3. Manual discharge from remote source as programmed. This method is good for fully automated systems via remote control room.
 - a. A 24V source capable of 20mA is connected to enable input via terminals inside cabinet.
 - i. Set up IGBT switch for normal operation (J1 in NORM position)
 - a. When 24V is applied the enable is given and the discharge cycle begins.
 - ii. Set up IGBT switch for inverted operation (J1 in INV position)
 - a. When 24V is applied the switch is held OFF. When voltage is removed the enable is given and the discharge cycle begins.

7.1.2. HOW TO FIGURE RMS CURRENT FOR CAPACITOR BANK DISCHARGE

Because the M3628T discharge switches do not have a continuous source of power, connecting wires do not need to be sized for full duty at the peak current rating. The following equation can be used to figure the rms current of a capacitor bank discharge.

$$I_{peak} = V_o / R$$

Where V_o is the initial voltage of the capacitor bank at discharge, and R is the discharge resistor value.

Wire sizing should be done using the RMS value of the current from the formula:

$$I_{rms} = \sqrt{\frac{1}{6\tau} \int_0^{5\tau} \left(\frac{V_o}{R} e^{-t/\tau}\right)^2 dt} \quad \text{where } \tau = R * C$$

This reduces to:

$$I_{rms} = \frac{V_o}{R} * (.29)$$

Example: A 600VDC capacitor bank with a 2 ohm discharge resistor will give a peak current of 300 amps. 300 amps multiplied by .29 shows that the rms current during the discharge is 87 amps, and the connecting wire can be sized for this 87 amps rms.

Keep in mind that the capacitor must be recharged before discharging again, so the actual rms current is much less due to this low duty cycle.

7.1.3. DISCHARGER FUSING APPLICATION NOTE

The purpose of the discharger system is to make the capacitor bank voltage safe for maintenance personnel in a reasonable period of time because self discharge of an ultracapacitor bank can take up to 2 weeks. Whether to add fusing in the discharge link depends on the local codes and end user requirements.

Reasons you may want to consider using a fuse

- If the resistor is mounted outside the discharge switch cabinet
- If the discharge switch is in a different cabinet than the capacitor bank

Reasons you may NOT want or need to use a fuse

- When there absolutely has to be a way to discharge the capacitor bank without any personnel touching a live circuit (a blown fuse will have voltage on the capacitor side of the open fuse)
- If all components are inside the same cabinet

In short, fusing protects wires between the capacitor bank and switch, but if the fuse ever opens prematurely there is no way to finish discharge, leaving the choices of waiting two weeks for self discharge or connecting to live voltage on capacitor bank fuse.

7.1.4. HOW TO CHOOSE A DISCHARGE SWITCH AND RESISTOR

Bonitron ultracapacitor discharge packages are based on the industrial standard of draining the energy storage bank down to below 50V in 1 minute. Discharge down to 15V will occur in less than 3 minutes.

- C = Capacitance in Farads
- V = Voltage
- R = Resistance
- J = Joules

- I = Current
- Capacitor banks are rated in voltage and Farads
- Resistors are rated in joules and peak voltage
- IGBT discharge switches are rated in voltage and peak current.

STEPS TO SIZING

1. Learn the specifications of the ultracapacitor storage bank
 - b. Full charged voltage
 - c. Capacitance

Example:

An ultracapacitor bank with ten series 48V, 165F caps will have a bank voltage of 480VDC (48V x 10_{series}), and a total capacitance of 16.5 Farads (165F ÷ 10_{series}).

2. Figure joules stored
 - a. $\frac{1}{2} CV^2 = J$
 - b. $.5 \times 16.5F \times 480V^2 = 1.9$ megajoules or 1900 kilojoules of energy stored
3. Choose resistor bank with more energy absorption than the capacitor bank stores
 - a. Resistor bank M3628R-H2000 (2000 kilojoules) will be needed to handle 1.9 megajoules
4. Match IGBT switch with 2000 kilojoule resistors
 - a. Tables 6-1 thru 6-4 match Switches and Resistors
 - i. based on discharge to 50V in 1 minute
 - ii. based on 150-800VDC capacitor banks
 - b. 300 amp rating will be needed to get 1.9 megajoule bank down to 50VDC in 1 minute.
5. Choose resistor ohmic value to match IGBT peak current rating @ capacitor voltage level
 - a. $R = V \div I$
 - b. $480V \div 300 \text{ amps} = 1.6$ ohms
6. Select 2000 kilojoule resistor that is equal to or one size lower in ohmic value. In this case 1.5 ohms along with a 300 amp switch will drain a 1.9 megajoule, 16.5F, 480VDC ultracapacitor bank down to 50VDC in 1 minute.

Figure 7-1: Discharge Resistor Selection Chart

