



Solutions for AC Drives

Model S3460UR

Ultracapacitor Ride-Thru System

Customer Reference Manual

Bonitron, Inc.
Nashville, TN



An industry leader in providing solutions for AC drives.

ABOUT BONITRON

Bonitron designs and manufactures quality industrial electronics that improve the reliability of processes and variable frequency drives worldwide. With products in numerous industries, and an educated and experienced team of engineers, Bonitron has seen thousands of products engineered since 1962 and welcomes custom applications.

With engineering, production, and testing all in the same facility, Bonitron is able to ensure its products are of the utmost quality and ready to be applied to your application.

The Bonitron engineering team has the background and expertise necessary to design, develop, and manufacture the quality industrial electronic systems demanded in today's market. A strong academic background supported by continuing education is complemented by many years of hands-on field experience. A clear advantage Bonitron has over many competitors is combined on-site engineering labs and manufacturing facilities, which allows the engineering team to have immediate access to testing and manufacturing. This not only saves time during prototype development, but also is essential to providing only the highest quality products.

The sales and marketing teams work closely with engineering to provide up-to-date information and provide remarkable customer support to make sure you receive the best solution for your application. Thanks to this combination of quality products and superior customer support, Bonitron has products installed in critical applications worldwide.

AC DRIVE OPTIONS

In 1975, Bonitron began working with AC inverter drive specialists at synthetic fiber plants to develop speed control systems that could be interfaced with their plant process computers. Ever since, Bonitron has developed AC drive options that solve application issues associated with modern AC variable frequency drives and aid in reducing drive faults. Below is a sampling of Bonitron's current product offering.

WORLD CLASS PRODUCTS

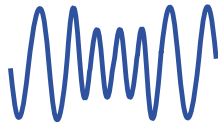

Undervoltage Solutions
Uninterruptible Power for Drives
(DC Bus Ride-Thru)
Voltage Regulators
Chargers and Dischargers
Energy Storage

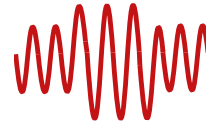

Overvoltage Solutions
Braking Transistors
Braking Resistors
Transistor/Resistor Combo
Line Regeneration
Dynamic Braking for Servo Drives



Common Bus Solutions
Single Phase Power Supplies
3-Phase Power Supplies
Common Bus Diodes



Portable Maintenance Solutions
Capacitor Formers
Capacitor Testers

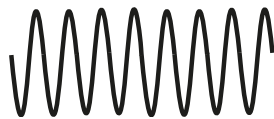

Power Quality Solutions
12 and 18 Pulse Kits



Green Solutions
Line Regeneration

This page intentionally left blank

- 1. INTRODUCTION.....7**
 - 1.1. Who Should Use..... 7
 - 1.2. Purpose and Scope..... 7
 - 1.3. Manual Version 7
 - Figure 1-1: S3460UR Ride-Thru System7
 - 1.4. Symbol Conventions Used in this Manual and on Equipment 8
- 2. PRODUCT DESCRIPTION.....9**
 - 2.1. Related Products 9
 - 2.1.1. Products9
 - 2.2. Part Number Breakdown 10
 - Figure 2-1: Example of Part Number Breakdown.....10
 - Table 2-1: System Voltage Rating Codes 10
 - Table 2-2: Display Panel Configurations 11
 - Table 2-3: Cabinet Codes.....11
 - 2.3. General Specifications 12
 - Table 2-4: S3460UR General Specifications 12
 - 2.4. General Precautions and Safety Warnings 13
- 3. INSTALLATION INSTRUCTIONS.....15**
 - 3.1. Environment 15
 - 3.2. Unpacking..... 15
 - 3.3. Mounting 15
 - 3.4. Wiring and Customer Connections..... 15
 - 3.4.1. Power Wiring.....15
 - Table 3-1: S3460UR Input Power Wiring Sizes and Fusing.....17
 - Table 3-2: User I/O Terminal Connections for Cabinets17
 - Figure 3-1: Power Connections.....18
 - Figure 3-2: User I/O Connections Detail18
 - Figure 3-3: User I/O Connections with DD5 Interface Module19
 - Figure 3-4: M3460R Typical Configuration with Energy Storage and M3528 Charger.....20
 - Figure 3-5: M3460R Typical Configuration with Energy Storage and M5628 Charger.....21
- 4. OPERATION.....23**
 - 4.1. Functional Description 23
 - 4.2. Startup Procedure 23
 - 4.2.1. Pre-Power Checks.....23
 - 4.3. Ultracapacitor Discharge Procedure 24
- 5. MAINTENANCE AND TROUBLESHOOTING.....25**
 - 5.1. Field Test Procedure 25
 - 5.2. Troubleshooting..... 26
 - Table 5-1: Troubleshooting Guide 26
 - 5.3. Technical Help – Before You Call 28
- 6. ENGINEERING DATA.....29**
 - 6.1. Ratings 29
 - 6.2. Watt Loss (Inactive Power Consumption)..... 29
 - 6.3. Rating Charts 29
 - Table 6-1: Model Specifications 29
 - Table 6-2: Voltage Specifications Table 29
 - 6.4. Dimensions and Mechanical Drawings 30
 - Figure 6-1: D82 Cabinet Dimensional Outline 30
 - Figure 6-2: D85 Cabinet Dimensional Outline 31
 - Figure 6-3: D86 Cabinet Dimensional Outline 32
 - Figure 6-4: D87 Cabinet Dimensional Outline 33

This page intentionally left blank

1. INTRODUCTION

1.1. WHO SHOULD USE

This manual is intended for use by anyone who is responsible for integrating, installing, maintaining, troubleshooting, or using this equipment with any AC drive system. Please keep this manual for future reference.

1.2. PURPOSE AND SCOPE

This manual is a user's guide for the model S3460UR ultracapacitor ride-thru systems. It will provide the user with the necessary information to successfully install, integrate, and use these in a variable frequency AC drive system.

In the event of any conflict between this document and any publication and/or documentation related to the AC drive system, the latter shall have precedence.

1.3. MANUAL VERSION

The initial release of the S3460UR manual is Rev 00a.

Updated to include the DD5 digital display in Rev 01a.

Updated table 3-2 in Rev 01b.

Updated section 4.3 in Rev 01c.

Updated figure 3-5 in Rev 01d.





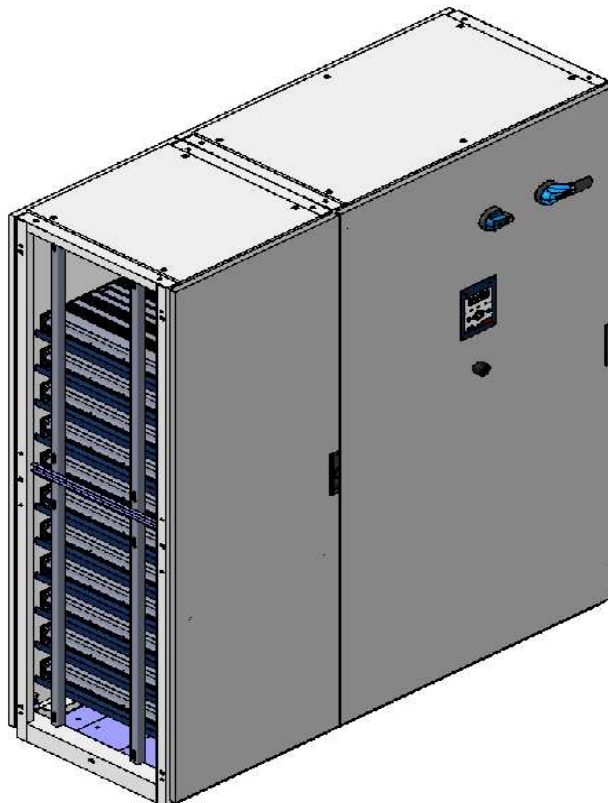

Updated enclosure dimensions in Rev 01e.

Updated figures 6-1, 6-2, 6-3, & 6-4, and amended page formatting in Rev 01f.

Figure 1-1: S3460UR Ride-Thru System



1.4. SYMBOL CONVENTIONS USED IN THIS MANUAL AND ON EQUIPMENT

	<p>Earth Ground or Protective Earth</p>
	<p>AC Voltage</p>
	<p>DC Voltage</p>
 <p>DANGER!</p>	<p>DANGER: Electrical hazard - Identifies a statement that indicates a shock or electrocution hazard that must be avoided.</p>
 <p>DANGER!</p>	<p>DANGER: Identifies information about practices or circumstances that can lead to personal injury or death, property damage, or economic loss.</p>
 <p>CAUTION!</p>	<p>CAUTION: Identifies information about practices or circumstances that can lead to property damage, or economic loss. Attentions help you identify a potential hazard, avoid a hazard, and recognize the consequences.</p>
 <p>CAUTION!</p>	<p>CAUTION: Heat or burn hazard - Identifies a statement regarding heat production or a burn hazard that should be avoided.</p>

2. PRODUCT DESCRIPTION

Bonitron S3460UR series of DC bus ride-thru systems provide protection from line voltage outage for variable frequency drives (VFDs) that use a fixed rectifier and DC bus. Providing power for outage times up to 2 seconds.

Industries with continuous processes can suffer huge losses from equipment downtime, loss of production, or damaged product when VFDs trip on undervoltage conditions. While many drives claim to have ride through capability such as auto restart or kinetic buffering, none can control the motor during a complete loss of power. Typical UPS solutions are designed to increase drive availability, but are connected in series which decreases overall drive system reliability. All Bonitron ride-thru products connect in parallel with the drive, thus increasing system availability and reliability.

Bonitron S3460UR systems provide sufficient ride through capability to handle these outages by storing energy in ultracapacitor banks and releasing it back into the drives' DC bus when needed. This allows the drive to "ride-thru" these events while maintaining motor speed and torque without experiencing drive shutdown.

A complete S3460UR ultracapacitor backup system includes a charger, ultracapacitor, discharger kit, discharge resistor, and booster module.

ADVANTAGES

- Reliability
- Parallel connection to AC system
- Works with almost any fixed bus, variable frequency, PWM drive
- Only 2-3 parallel connections
- Can use existing AC feed wiring and breakers
- Instant response
- Bumpless transfer
- Easy commissioning

2.1. RELATED PRODUCTS

2.1.1. PRODUCTS

M3460 SERIES RIDE-THRU MODULES

Voltage regulators used for sag or outage protection of higher power systems.

M5628 BATTERY AND ULTRACAPACITOR CHARGERS

Chargers for high voltage storage strings.

S3460SR SERIES SAG RIDE-THRU SYSTEMS

An enclosed system for 50%-line sag for 2 seconds or a single phase full outage for up to 2 seconds

S3460BR SERIES BATTERY RIDE-THRU SYSTEMS

An enclosed system for full outage up to 4 minutes.

KIT 3628T AND M3628R ULTRACAPACITOR DISCHARGER AND RESISTOR

The M3628T and M3628R discharger and resistor safely discharges the ultracapacitors to a safe voltage level quickly.

2.2. PART NUMBER BREAKDOWN

Figure 2-1: Example of Part Number Breakdown

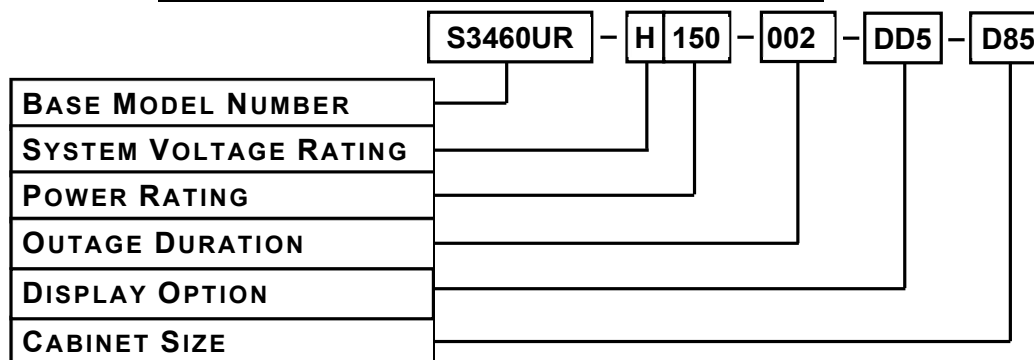

BASE MODEL NUMBER

The base model number for all enclosed ultracapacitor ride-thru systems is S3460UR.

SYSTEM VOLTAGE RATING

The system voltage rating indicates the nominal AC / DC voltage levels of the AC drive system the ride-thru is intended to support. A code letter indicates the system voltage.

Table 2-1: System Voltage Rating Codes

RATING CODE	VOLTAGES (NOMINAL AC LINE / DC BUS)
L	230VAC / 320VDC
E	380 - 415VAC / 540 - 585VDC
H	460VAC / 640VDC

POWER RATING (KW)

The power rating indicates the maximum power in kilowatts that can safely be handled by the S3460UR and is represented by a 3-digit value based on the nominal DC system voltage rating and the maximum output current rating of the S3460UR. For instance, the code **150** indicates a 150kW S3460UR.

OUTAGE DURATION

The outage duration indicates the amount of time (in seconds) the M3460R module is able to hold the DC bus at the threshold level while loaded to the rated current. This duration is directly represented by a 3-digit value. For example, **002** represents **2** seconds of outage duration.

DISPLAY OPTION

The display option indicates which display is mounted on the front of the enclosure. The displays show the S3460UR operating status and permit a system test to be performed. The DD5 digital display has many more features than the DP10 analog display, including outage and fault logging. Please refer to the KIT 3660DD5 manual for a full description of features.

Table 2-2: Display Panel Configurations

DISPLAY MODEL	LOCAL INDICATORS	VOLTMETER	AMMETER	TOTAL COUNTER	RESETTABLE COUNTER	ACTIVITY LOGGING	LOCAL TEST INITIATION
DD5	✓	✓	✓	✓	✓	✓	✓
DP10	✓				✓		✓

CABINET SIZE

The model S3460UR ultracapacitor system is available in various cabinet sizes. Size is dependent on the boost module's kW rating. The cabinet size is indicated by a code as shown in Table 2-3. See Section 6.4 for complete dimensional outline. (*) system comprising multiple enclosures baying together does not have a cabinet code.

Table 2-3: Cabinet Codes

CABINET CODE	VOLTAGE RATING	POWER RATING	DESCRIPTION
D82	L	25 kW	79" H x 40" W x 20" D, UL Type-12 floor mount enclosure
	E	43 kW	
	H	50 kW	
*	L	38KW,50 kW	71" H x 56" W x 24" D, UL Type-12 floor mount enclosure
	E	65KW,87 kW	
	H	75KW,100 kW	
*	L	75 kW, 100 kW	79" H x 56" W x 24" D, UL Type-12 floor mount enclosure
	E	130 kW, 175 kW	
	H	150 kW, 200 kW	
*	L	125 kW	79" H x 63" W x 24" D, UL Type-12 floor mount enclosure
	E	215 kW	
	H	250 kW	

2.3. GENERAL SPECIFICATIONS

Table 2-4: S3460UR General Specifications

PARAMETER	SPECIFICATION	
System AC Voltage	230,380-415, 460 VAC	
Output DC Voltage Range	320 – 640 VDC	
Threshold Voltage Level	285 – 585 VDC	
DC Bus Current Rating (Max)	85 – 425 ADC	
Power Rating (Range)	25 – 250 kW	
Outage Duration	0.5 – 2.0 seconds	
Operating temperature	0 - 40° C	
Storage Temperature	-20 - 65° C	
Status Output Signals	Opto FET 350V, 120mA	
Humidity	Below 90% non-condensing	
Atmosphere	Free of corrosive gas and conductive dust	
Logic I/O	Inputs 24VDC <ul style="list-style-type: none"> • OV / UV Reset • Charge Enable • Boost Enable 	Outputs 20 - 28VDC <ul style="list-style-type: none"> • Battery Status • Charge Status • System Status1 • System Status 2 • Disconnect Switch Status

2.4. GENERAL PRECAUTIONS AND SAFETY WARNINGS



DANGER!

- **HIGH VOLTAGES MAY BE PRESENT!**
- **NEVER ATTEMPT TO OPERATE THIS PRODUCT WITH THE ENCLOSURE COVER REMOVED!**
- **NEVER ATTEMPT TO SERVICE THIS PRODUCT WITHOUT FIRST DISCONNECTING POWER TO AND FROM THE UNIT.**
- **ALWAYS ALLOW ADEQUATE TIME FOR RESIDUAL VOLTAGES TO DRAIN BEFORE REMOVING THE ENCLOSURE COVER.**
- **FAILURE TO HEED THESE WARNINGS MAY RESULT IN SERIOUS BODILY INJURY OR DEATH!**



CAUTION!

- **CERTAIN COMPONENTS WITHIN THIS PRODUCT MAY GENERATE HIGH AMBIENT TEMPERATURES DURING OPERATION.**
- **ALWAYS ALLOW AMPLE TIME FOR THE UNIT TO COOL BEFORE ATTEMPTING SERVICE ON THIS PRODUCT.**
- **BEFORE ATTEMPTING INSTALLATION OR REMOVAL OF THIS PRODUCT, BE SURE TO REVIEW ALL DRIVE AND/OR RESISTIVE LOAD DOCUMENTATION FOR PERTINENT SAFETY PRECAUTIONS.**
- **INSTALLATION AND/OR REMOVAL OF THIS PRODUCT SHOULD ONLY BE ACCOMPLISHED BY A QUALIFIED ELECTRICIAN IN ACCORDANCE WITH NATIONAL ELECTRICAL CODE OR EQUIVALENT REGULATIONS.**
- **THIS PRODUCT DOES NOT PROVIDE MOTOR OVERLOAD PROTECTION.**

ANY QUESTIONS AS TO APPLICATION, INSTALLATION, OR SERVICE SAFETY SHOULD BE DIRECTED TO THE EQUIPMENT SUPPLIER.

This page intentionally left blank

3. INSTALLATION INSTRUCTIONS



Installation and/or removal of this product should only be performed by a qualified electrician in accordance with National Electrical Code or local codes and regulations.

Proper installation of the S3460UR ultracapacitor ride-thru should be accomplished following the steps outlined below. Be sure to refer to the AC drive instruction manual as these steps are performed. Please direct all installation inquiries that may arise during the installation and startup of this product to the equipment supplier or system integrator.

3.1. ENVIRONMENT

The maximum operating temperature of the ride-thru system should not exceed 40°C.

3.2. UNPACKING

Upon receipt of this product, please verify that the product received matches the product that was ordered and that there is no obvious physical damage to the unit. If the wrong product was received or the product is damaged in any way, please contact the supplier from which the product was purchased.

3.3. MOUNTING

1. Move the cabinet to the desired installation site.
2. Remove the hardware securing the cabinet to its pallet.
3. Using a crane or hoist connected to the cabinet's lifting eyes, remove the cabinet from the pallet, and set it in the desired location.
 - Secure the S3460UR cabinet in place. Cabinets may be anchored to the floor as necessary.
 - Mount the ultracapacitor discharge resistor within 20 feet of the capacitor bank.

3.4. WIRING AND CUSTOMER CONNECTIONS

Review this entire section before attempting to wire the S3460UR.

3.4.1. POWER WIRING



***THE M3460 CAN HAVE MULTIPLE POWER SOURCES, INCLUDING THE MAIN AC INPUT, ENERGY STORAGE SYSTEMS AND THE DC CONNECTION TO THE VFD.
ENSURE THAT ALL SOURCES ARE DISCONNECTED AND LOCKED OUT BEFORE ATTEMPTING SERVICE OR INSTALLATION.
FAILURE TO HEED THESE WARNINGS MAY RESULT IN SERIOUS INJURY OR DEATH!***

This section provides information pertaining to the field wiring connections of the S3460UR ride-thru cabinet system. Actual connection points and terminal numbers of the AC drive system will be found in the documentation provided with that drive system.

Be sure to review all pertinent AC drive system documentation before proceeding.

3.4.1.1. POWER CONNECTIONS

AC LINE (L1, L2, L3) CONNECTIONS

During operation, the load on the AC line is used for charging and maintaining the ultracapacitor storage modules.

See Section 6.3 for the full load and standby AC ratings.

DC BUS (+ -) CONNECTIONS

The S3460UR must have a DC bus connection directly to the DC bus filter capacitors within the drives. Connections cannot be made through the braking terminals or with precharge resistors or DC link chokes between the output of the S3460UR and the DC bus capacitors in the drive. Consult the manufacturers' documentation or contact Bonitron for further assistance.

Make sure the polarity is correct for these connections, as failure to do so can cause severe damage to the system.

GROUNDING REQUIREMENTS

Cabinet should be earth grounded to the stud in upper right corner of the backplate.

Ultracapacitor Bank Wiring

The following data is supplied for assistance in selecting the appropriate field wiring sizes and power source fuse ratings for the model S3460UR cabinet ride-thru systems.

- Wire size must be coordinated with circuit protection devices and IR drop of wire. It is NOT necessary to size the wire for continuous duty. The maximum allowed duty cycle for the S3460UR ride-thru is two, 2 second cycles per minute, per hour.
- Steady state Class J time delay or equivalent power source fusing should be used to support the requirement for 2-second 2x surge capability. The recommended minimum current rating for the power source fusing is listed in Table 3-1 below, based on the DC bus current rating of the ride-thru module.
- The field wiring sizes listed in Table 3-1 below assume a 10 V drop for wire lengths of 100 feet and are compatible with the recommended steady state power source fusing listed. The wire gauge selected for field wiring to the ride-thru should be equal to or greater than that listed in Table 3-1. The maximum wire gauge that can physically be accepted by the disconnects for cabinet mounted systems is 4/0.

Table 3-1: S3460UR Input Power Wiring Sizes and Fusing

SYSTEM KW	RIDE-THRU DC BUS CURRENT RATING	MIN. SOURCE FUSING (CLASS J TIME DELAY)	RECOMMENDED FIELD WIRING SIZES	MCM EQUIVALENT WIRING SIZES
40 - 62	85 A	70 A	2 AWG	67 MCM
62 - 93	130 A	100 A	2 AWG	67 MCM
80 - 125	170 A	125 A	1 AWG	84 MCM
135 - 187	255 A	175 A	2/0 AWG	133 MCM
165 - 250	340 A	225 A	3/0 AWG	168 MCM
165 - 250	425 A	275 A	4/0 AWG	250 MCM

Use copper wiring rated for 75°C for all connections.

3.4.1.2. CONTROL INTERFACE AND I/O WIRING

The Control Interface and I/O Wiring are from the M3460 ride-thru module. Please see the M3460 manual for further information on these outputs.

See Figure 3-1 for terminal locations.

Table 3-2: User I/O Terminal Connections for Cabinets

TERMINAL	FUNCTION
TB – 1	Courtesy + 24V
TB – 2	Charger ENABLE
TB – 3	Ride-Thru ENABLE
TB – 4	Ride-Thru TEST
TB – 5	Input COM
TB – 6	Courtesy COM
TB – 7	Fault 1
TB – 8	Fault 2
TB – 9	Ride-Thru Active (RTA)
TB – 10	Output COM
TB – 11	Storage Undervoltage (NO)
TB – 12	Storage Undervoltage COM

Figure 3-1: Power Connections

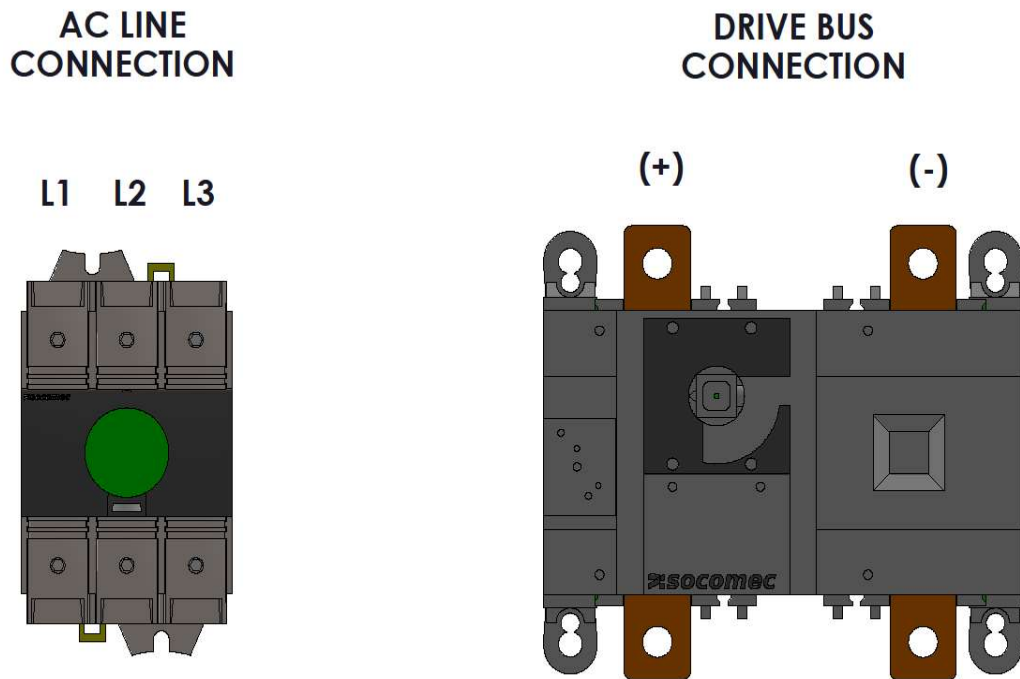
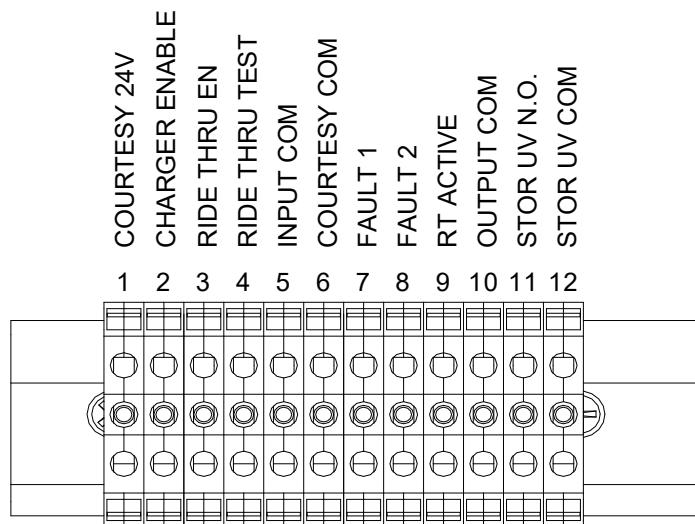

Figure 3-2: User I/O Connections Detail



I/O CONNECTIONS

Figure 3-3: User I/O Connections with DD5 Interface Module

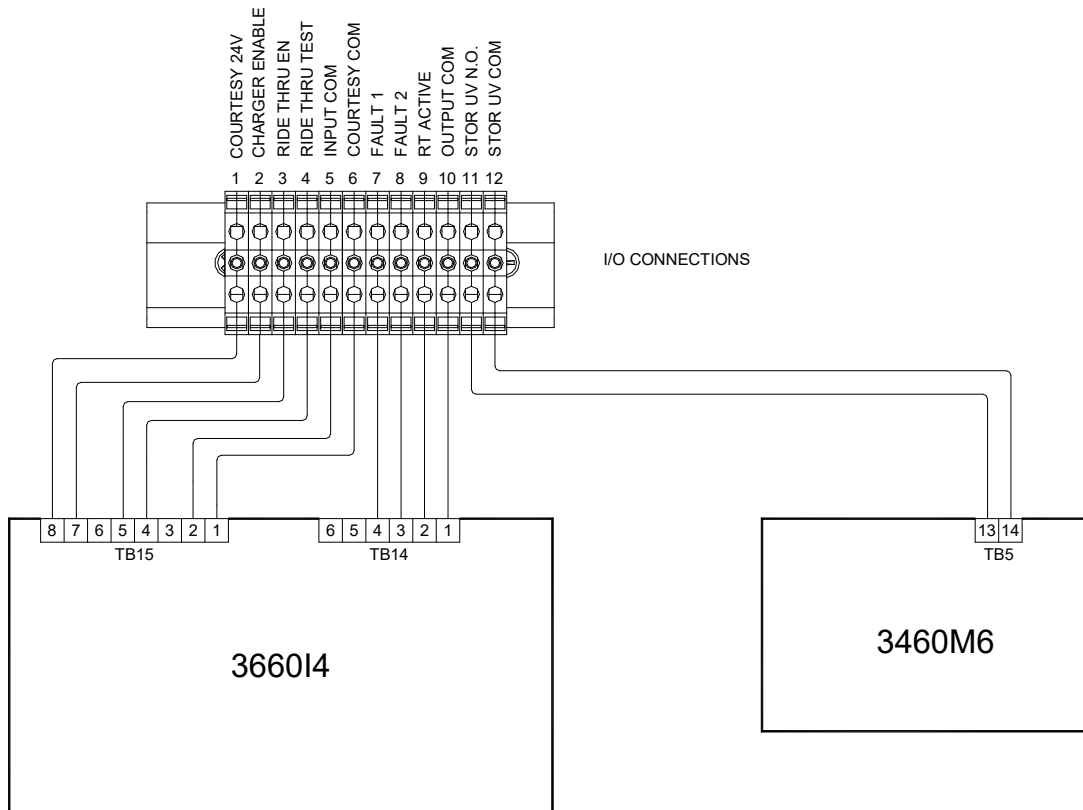
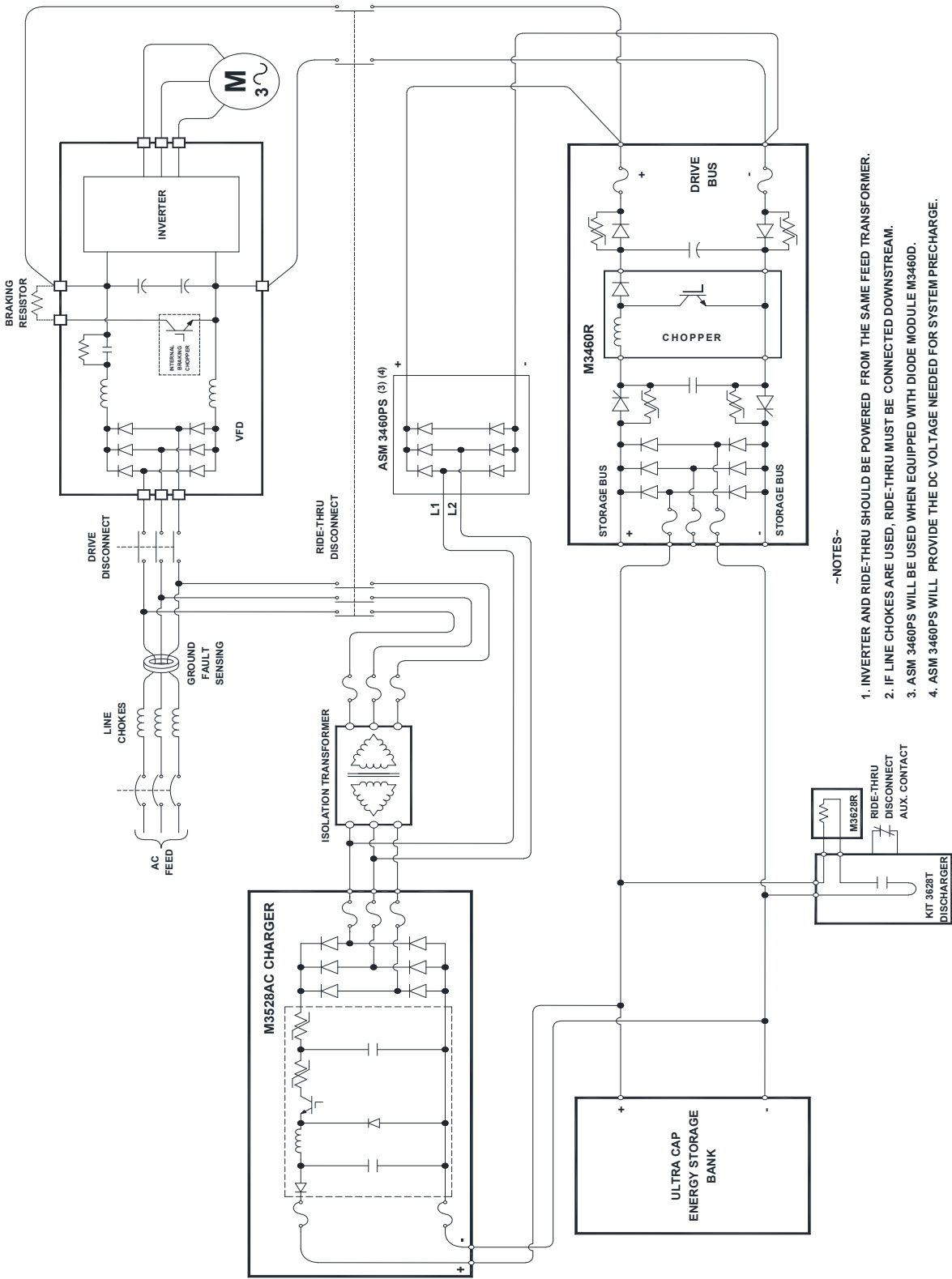

Figure 3-4: M3460R Typical Configuration with Energy Storage and M3528 Charger



- NOTES-
1. INVERTER AND RIDE-THRU SHOULD BE POWERED FROM THE SAME FEED TRANSFORMER.
 2. IF LINE CHOKES ARE USED, RIDE-THRU MUST BE CONNECTED DOWNSTREAM.
 3. ASM 3460PS WILL BE USED WHEN EQUIPPED WITH DIODE MODULE M3460D.
 4. ASM 3460PS WILL PROVIDE THE DC VOLTAGE NEEDED FOR SYSTEM PRECHARGE.

Figure 3-5: M3460R Typical Configuration with Energy Storage and M5628 Charger

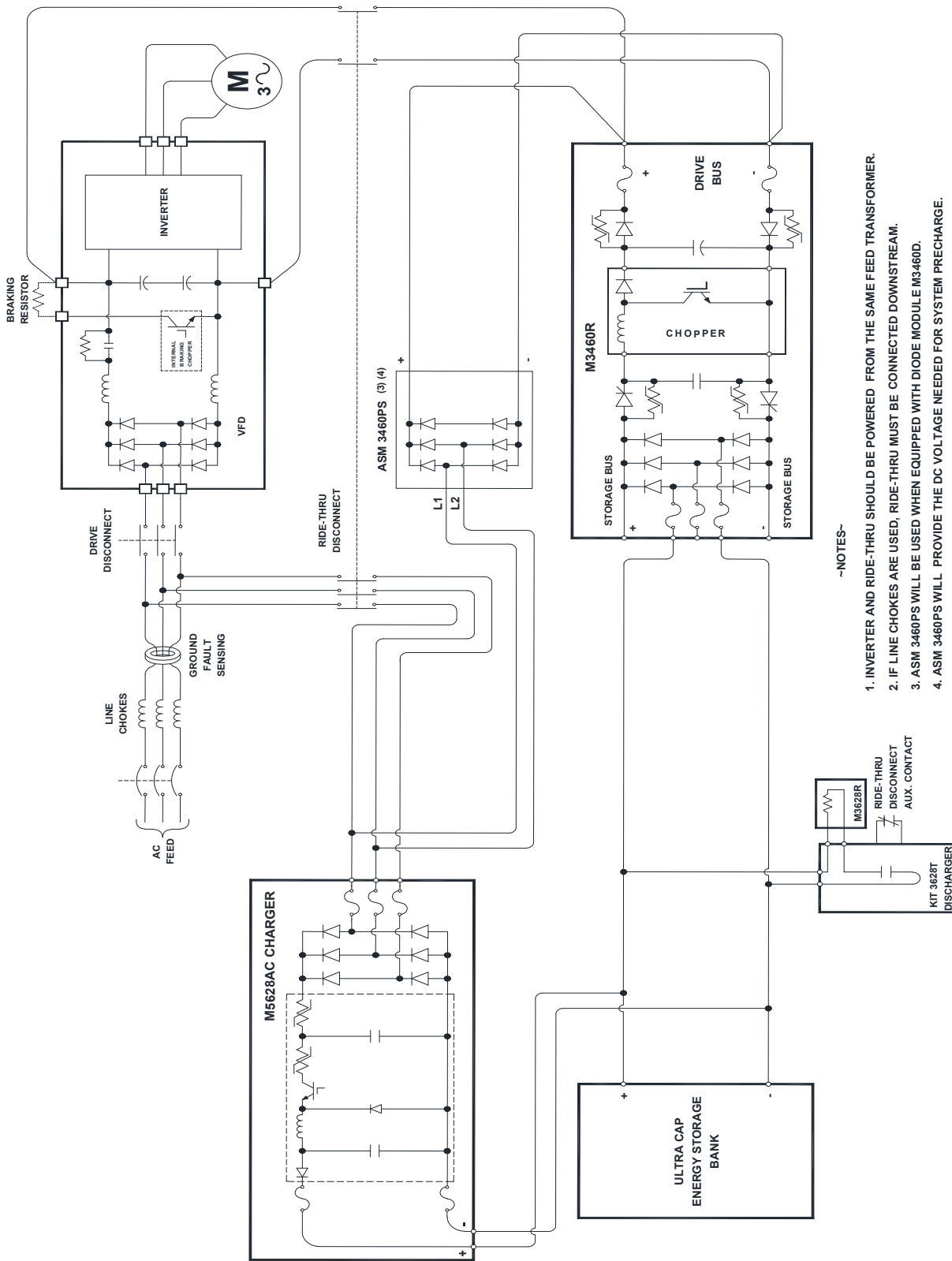
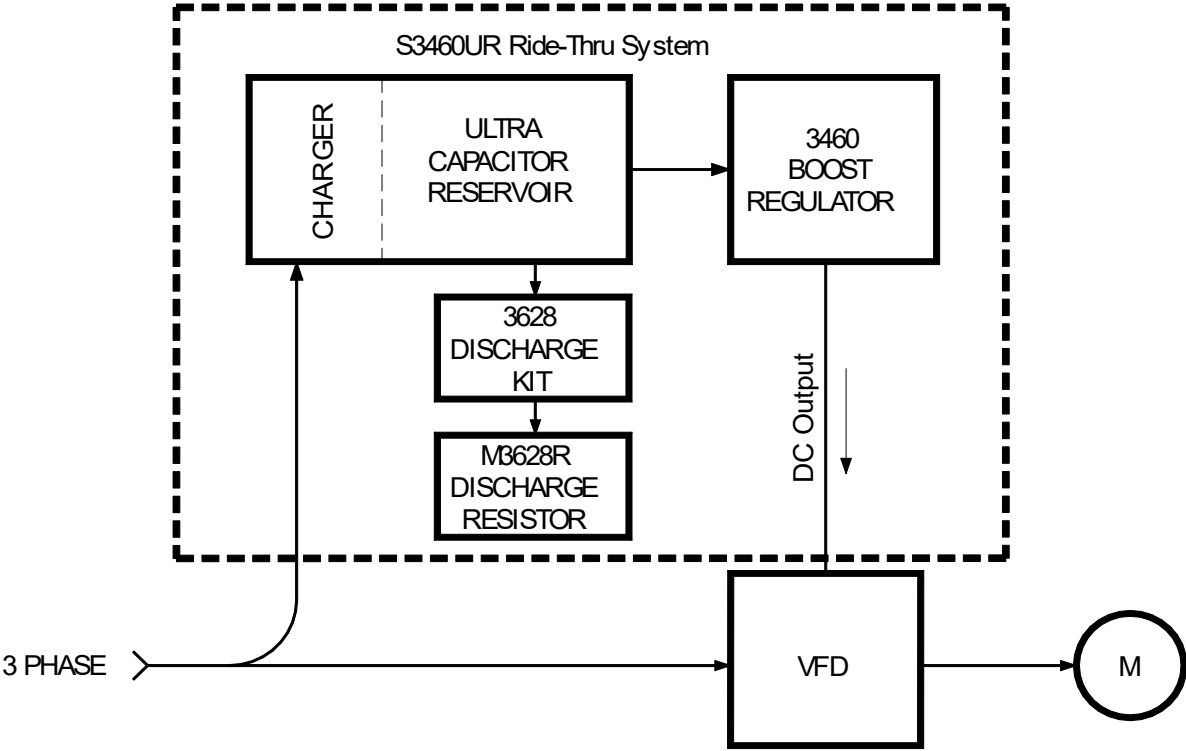

Figure 3-6: Ride-Thru System Configuration



4. OPERATION

4.1. FUNCTIONAL DESCRIPTION

The S3460UR ride-thru system monitors the DC bus of the attached variable frequency drive (VFD) and provides power in a voltage controlled, current limited supply directly to the filter capacitor section of the drive above the inverter stage. During a power quality event, such as a sag or power outage, the internal DC bus of the VFD drops. When this level meets the DC bus threshold voltage of the S3460UR, power is delivered through blocking diodes to hold up the voltage in the VFD bus.

Energy is stored in an ultracapacitor bank and the boost module regulates and boosts the output voltage to the drive at a constant voltage.

The ultracapacitor modules are wired in series configuration to get voltages up to a usable level and in parallel for more energy storage.

In standby mode, or when the incoming AC power is normal, the system recharges the ultracapacitor bank and holds the energy storage at a constant level. Once the capacitor bank is charged, the standby energy consumption is minimal.

4.2. STARTUP PROCEDURE

4.2.1. PRE-POWER CHECKS

1. Ensure the Bonitron ride-thru has been properly installed as per the instructions in Section 3 of this manual.
2. Check the polarity of the DC Bus connection to the VFD at the disconnect. It is critical that this is correct.
3. The ride-thru DC bus threshold must be coordinated with the undervoltage trip setting of the VFD. If the threshold is too close to the nominal bus, the ride-thru may supply power to the drive continuously and overheat. If the threshold is too close to the undervoltage trip level of the VFD, the system may not "Ride-Thru", and under voltage trips will still occur. Most VFDs have an undervoltage trip point of -15% of the nominal voltage level.

Bonitron sets all ride-thru threshold levels at -10% of the nominal DC bus voltage level. For example, all 460 VAC systems will hold the DC bus level at 585 VDC.

4. Refer to the drive manual for details on adjustment of the undervoltage trip setting, it is typically 80-85% of the full DC bus voltage.
5. Power up the attached drive system. This should be done according to the procedure for the VFD. Ensure that the associated VFD is working properly prior to connecting to the ride-thru system.

4.3. ULTRACAPACITOR DISCHARGE PROCEDURE

1. Turn OFF the AC line disconnect; this will disconnect the incoming AC line voltage to the charger module.
2. Turn off the DRIVE BUS disconnect. This will disconnect the output DC power to the VFD. Turning OFF the DC disconnect will automatically close the internal contactor to discharge the capacitor bank within 60 seconds to a safe level below 50VDC.
 - Open the cabinet and turn ON the BYPASS switch, this will keep the discharge resistor across the capacitor bank to prevent a residual charge from building up.
 - Remember to turn OFF the bypass switch when the system is ready to power up.

5. MAINTENANCE AND TROUBLESHOOTING

Repairs or modifications to this equipment are to be performed by Bonitron approved personnel only. Any repair or modification to this equipment by personnel not approved by Bonitron will void any warranty remaining on this unit.

5.1. FIELD TEST PROCEDURE

The Bonitron S3460UR ride-thru system is designed to be low maintenance. However, the connected energy storage bank will degrade over time, and should be periodically checked. Bonitron recommends a yearly test of the system to ensure the electronics package is operating properly, and the storage bank has proper capacity. The following steps can be taken to ensure reliability that the system is still able to ride-thru an outage event.

Each Bonitron ride-thru should be tested under load during initial start up to verify the functionality of the test circuit and that the test does not negatively affect the process. However, Bonitron recommends that if the process is critical, the test cycle be initiated only during a scheduled shutdown.

1. Ensure the S3460UR has been properly installed according to the wiring diagram.
2. Ensure the AC line input and drive DC bus are all installed properly to the cabinet disconnect. Ensure the ultracapacitor bank, charger, and the discharge kit are installed properly.
3. Turn on power to the drive and ensure it is working properly without any fault, **the drive must be ON before applying power to the Ride-Thru.**
4. Turn on the cabinet disconnects and observe the display status. The status should display Ride-Thru STANDBY and charger STANDBY. If there are faults on the system, turn off power and check the KIT 3660DD5 and the M3460 manuals for further troubleshooting details.
5. While charging the capacitor bank, the display will show STORAGE UNDER VOLTAGE fault, the fault can be cleared when the capacitors are about 65% charged.
6. Load the VFD as much as is practical for testing.
7. Initiate the test mode with the display panel to confirm that the booster is working properly.
The DC bus should rise for about 100VDC above the normal DC bus level.
8. Verify energy storage bank charge by removing AC power to the Drive simulating an outage event.
 - The DC bus voltage should drop to the threshold voltage level.
 - Ride-Thru Active indicator turns ON.
 - DC bus voltage should hold at the threshold voltage level.
 - The drive should continue to run normally.
 - Motor speed should remain constant.
 - The system should only be allowed to run for a maximum of 2 seconds.
 - Re-apply the AC power to the inverter input.

This completes the maintenance procedure and the S3460UR and drive system should now be ready to be put into service.

5.2. TROUBLESHOOTING

Table 5-1: Troubleshooting Guide

SYMPTOM	ACTION
No LEDs	<ul style="list-style-type: none"> ▪ Check incoming power ▪ Check power supply 3460D5 for all voltages – replace if incorrect ▪ Check 24V RUN command
No +15 or -15 LEDs	<ul style="list-style-type: none"> ▪ Check power supply 3460D5 for all voltages – replace if incorrect ▪ If OK, then replace 3460C1 control PCB
No RTR	<ul style="list-style-type: none"> ▪ Check for RUN command ▪ Check stage fuses – look for blown fuse LED on 3460C1 ▪ Check 3460M6 interface ▪ IF OK replace 3460C1 control PCB
No PCC	<ul style="list-style-type: none"> ▪ Check DC bus level – if not OK check pre-charge circuits or bus caps ▪ Check for RUN command ▪ Check stage fuses – look for blown fuse LED on 3460C1 ▪ Check 3460M6 interface ▪ IF OK replace 3460C1 control PCB
Voltage Fault	<ul style="list-style-type: none"> ▪ Check input fuses ▪ Check 3460X4 phase loss monitor ▪ Check 3460M6 interface
RTA always ON	<ul style="list-style-type: none"> ▪ Check DC bus levels on both sides of diodes ▪ Check for overheated pre-charge circuit <ul style="list-style-type: none"> ▪ Too much activity can cause stage fuse failures, overheating and draining of the battery ▪ Check threshold level, if changed over time adjust level or replace 3460C1
RTA never ON	<ul style="list-style-type: none"> ▪ Check RUN command ▪ Initiate test cycle or remove power <ul style="list-style-type: none"> ▪ Watch and listen for signs of activity <ul style="list-style-type: none"> • Check RTA contact and LEDs • Ticking sound when active ▪ Check power quality data to confirm sag events should have caused activity to occur ▪ If there is no activity, then replace 3460C1

SYMPTOM	ACTION
Overtemp	<ul style="list-style-type: none"> ▪ Check for constant current on the negative and positive DC bus links ▪ Check temp sensors <ul style="list-style-type: none"> ▪ On SCR heatsink ▪ On diode heatsinks ▪ On IGBT heatsinks ▪ On chokes (if used) ▪ Check pre-charge network for overheating – (cause of constant activity) ▪ If all OK replace 3460M6 interface PCB ▪ Check activity record–Too much activity causes overtemp
Blown Fuse LED ON	<ul style="list-style-type: none"> ▪ Check stage fuses – LED on 3460F fuse PCB will be ON or Fuse Indicator will indicate blown fuse ▪ If all stage fuses are OK replace 3460C control PCB
Blown stage fuses	<ul style="list-style-type: none"> ▪ Check for shorted IGBT <ul style="list-style-type: none"> ▪ Replace 3438C2 gate driver if IGBT is bad ▪ Check or replace stage choke current sensor ▪ Check or replace 3438S stage IGBT snubber ▪ Check activity record <ul style="list-style-type: none"> ▪ Too much activity causes fuse fatigue
TEST won't work	<ul style="list-style-type: none"> ▪ Check DC bus level – too high causes no test ▪ Check blown fuse LED during test – if on check stage fuses ▪ Check test input to 3460C1 ▪ If OK replace 3460C1
Voltage fluctuates during TEST mode	<ul style="list-style-type: none"> ▪ Check threshold and test boost level settings. Over-voltage shutdown can occur if settings are too high on 460V systems, causing an oscillation affect. <ul style="list-style-type: none"> ▪ Lower threshold level and retry ▪ Check for loss of feedback from DC bus to 3460C1
Stays in TEST mode	<ul style="list-style-type: none"> ▪ Replace 3460C1
Precharge overheated	<ul style="list-style-type: none"> ▪ Check DC bus ripple voltage. Too much ripple can cause PTCRs to overheat. <ul style="list-style-type: none"> ▪ Add parallel pre-charge PTCRs ▪ Change series pre-charge resistance ▪ Add fan to cool PTCRs ▪ Add isolated bias supply ▪ Precharge can only be done 3 consecutive times before overheating can occur



CAUTION!

REPAIRS OR MODIFICATIONS TO THIS EQUIPMENT ARE TO BE PERFORMED BY BONITRON APPROVED PERSONNEL ONLY. ANY REPAIR OR MODIFICATION TO THIS EQUIPMENT BY PERSONNEL NOT APPROVED BY BONITRON WILL VOID ANY WARRANTY REMAINING.

5.3. TECHNICAL HELP – BEFORE YOU CALL

If possible, please have the following information when calling for technical help:

- Exact model number of affected units
- Serial number of units
- Name and model number of attached drives
- Name of original equipment supplier
- Brief description of the application
- The AC line to line voltage on all 3 phases
- The storage bank voltage
- The DC Bus voltage
- KVA rating of power source
- Source configuration Wye/Delta and grounding

This information will help us support you much more quickly. Please contact us at (615) 244-2825 or through www.bonitron.com

6. ENGINEERING DATA

6.1. RATINGS

See M3460 manual for ratings for ride-thru module.

6.2. WATT LOSS (INACTIVE POWER CONSUMPTION)

See M3460, KIT3628T, and M5628 manuals for Watt Loss information.

6.3. RATING CHARTS

Fuses are installed by Bonitron on the M3460 ride-thru module. Fusing information is available in M3460 manual.

Table 6-1: Model Specifications

DC BUS CURRENT ①	RECOMMENDED FUSE RATING ②		SCCR RATINGS
	DRIVE BUS	AC LINE	
85 A	80 A, 700 V	125 A, 600 V	10 kA ^③
127 A	125 A, 700 V	200 A, 600 V	
170 A	175 A, 700 V	250 A, 600 V	
255 A	250 A, 700 V	400 A, 600 V	
340 A	350 A, 700 V	500 A, 600 V	18 kA ^④
425 A	400 A, 700 V	600 A, 600 V	

① The input power source must be capable of handling a 2-second current surge at twice the nominal rating for the M3460R. Maximum duty cycle is 1% at full rated load.

② Fuses recommended for use with the M3460R are Gould-Shawmut A70QS series, Buss FWP series, or equivalent semiconductor fuses. These are required for UL 508C compliance.

③ Suitable for use on a circuit capable of delivering not more than 10,000 RMS symmetrical amperes, 700 volts maximum when protected by recommended fuses.

④ Suitable for use on a circuit capable of delivering not more than 18,000 RMS symmetrical amperes, 700 volts maximum when protected by recommended fuses.

Table 6-2: Voltage Specifications Table

AC INPUT VOLTAGE	TOLERANCE	OUTPUT DC BUS NOMINAL VOLTAGE	THRESHOLD VOLTAGE	LOW DC BUS VOLTAGE FAULT
230 VAC	± 10%	320 VDC	285 VDC (adjustable from 220-300)	250 VDC
380 VAC	± 10%	530 VDC	485 VDC (adjustable from 440-540)	450 VDC
400 VAC	± 10%	560 VDC	495 VDC (adjustable from 440-540)	460 VDC
415 VAC	± 10%	580 VDC	500 VDC (adjustable from 440-540)	465 VDC
460 VAC	± 10%	640 VDC	585 VDC (adjustable from 525-625)	550 VDC

6.4. DIMENSIONS AND MECHANICAL DRAWINGS

Figure 6-1: D82 Cabinet Dimensional Outline. 50KW

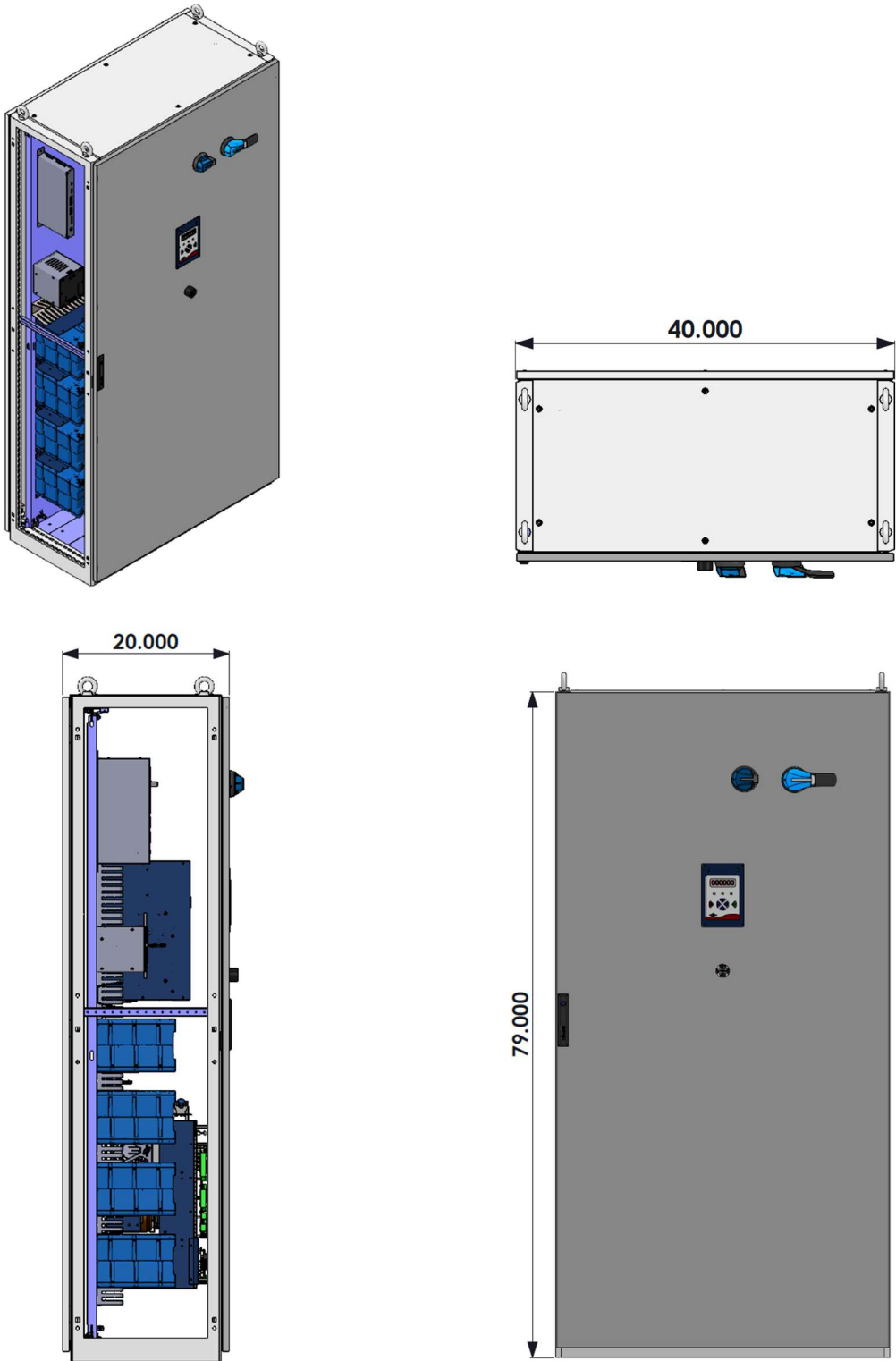

Figure 6-2: 75KW-100KW Cabinet Dimensional Outline

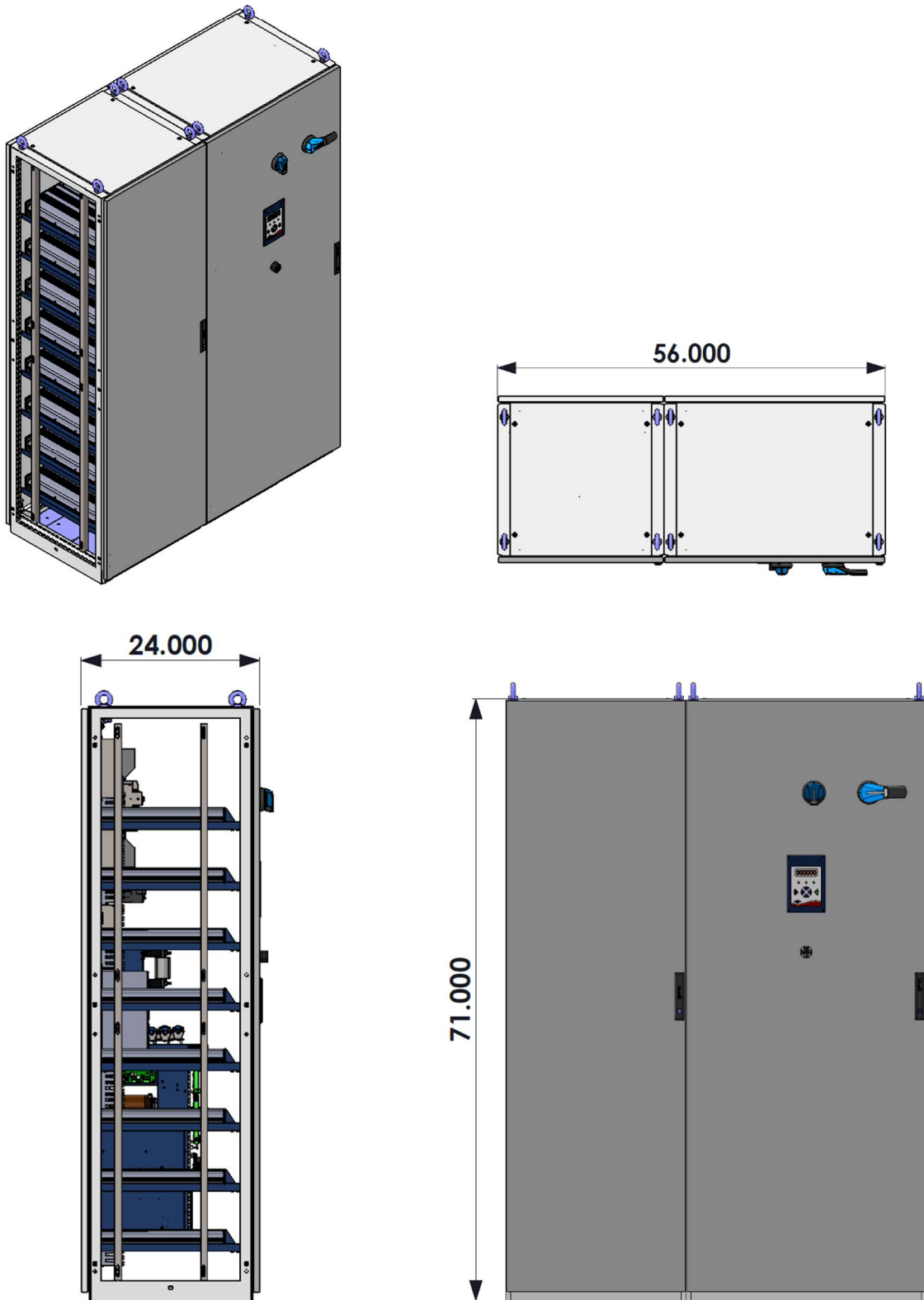

Figure 6-3: 150KW-200KW Cabinet Dimensional Outline

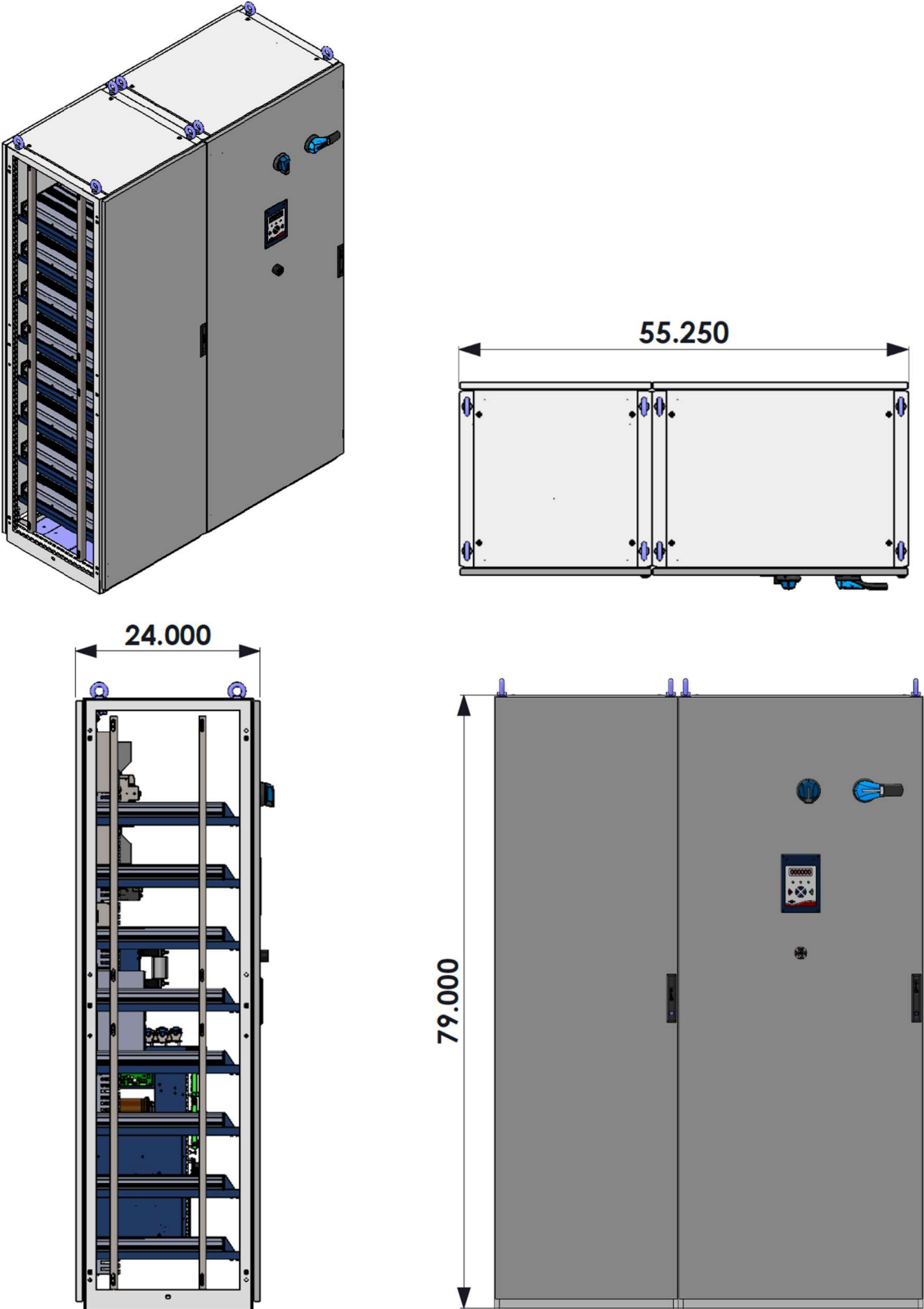
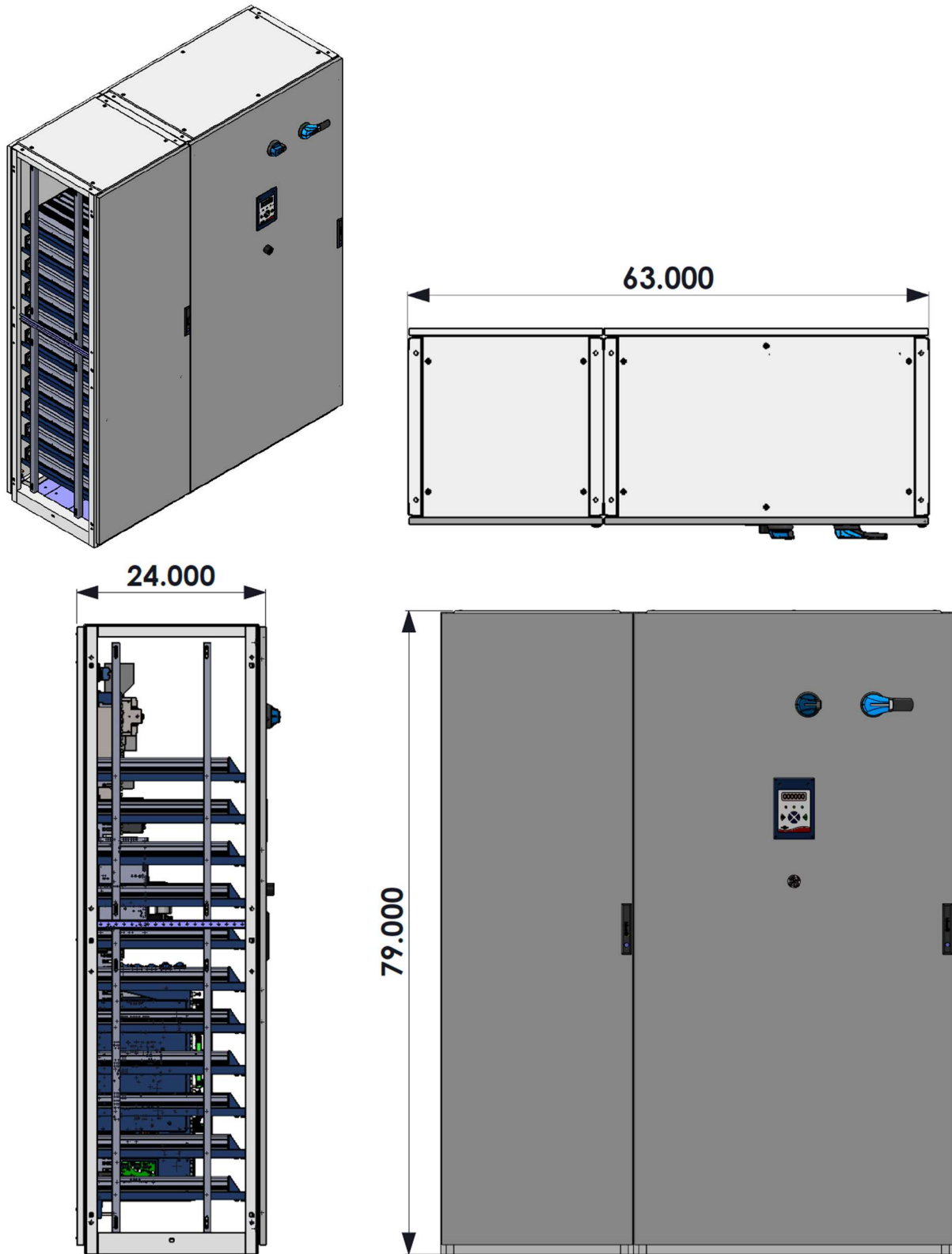

Figure 6-4: 250KW Cabinet Dimensional Outline



This page intentionally left blank

This page intentionally left blank

This page intentionally left blank

